

IQ

INNOVATION

QUARTERLY

INNOVATION. INSIGHT. INSIDE AEROSPACE.

Test of Time

Inside an airplane's journey from lab to wind tunnel to sky

Safety on Call

Behind the scenes with air safety investigators

Suit Up for Safety

Exoskeleton vest reduces strains and sprains

Machines Can See, Hear and Learn — From Humans

Human-centric machine learning in India

PLUS: Safety as a Culture

Boeing's Chief Aerospace Safety Officer offers an inside look

TEST DRIVE

Boeing test pilot Jennifer Henderson is part of a team that evaluates the 737-10.

 **BOEING**

PUBLISHER

Greg Hyslop
Chief Engineer

EDITORIAL DIRECTOR

Gary Wicks

EDITOR

Michael King

DIGITAL EDITOR

Vienna Catalani

CREATIVE LEAD

Dave Sizer

PROJECT MANAGER

Cassie Moore

DESIGN TEAM

William Crane, Vaughn Hale,
Cierra Johnson, Tony Tino

COPY EDITOR

Teresa Stanker

DIGITAL TEAM

Jan Bartko, Casey Gilman,
Shipra Gupta

LEGAL ADVISER

Don Tuegel

CONTRIBUTING EDITORS

Andrew Africk, Sandy Angers,
Rachel Ayres, Hannah Elgin, John Flick,
Annie Flodin, Melanie de Git,
Maks Goldenshteyn, Leslie Hazzard,
Paula Horton, Jill Hulings,
Jared Kaufer, Michael Lombardi,
Shaniqua Manning Muhammad,
Adam Mertz, Elizabeth Morris,
Daniel Moszynski, Katie Perdaris,
Soumitra Roy, Kelsey Swanson,
Will Wilson

COVER PHOTO

Dave Sizer/Boeing

JOIN US

jobs.boeing.com

LET'S TALK

Feedback is welcome at
IQ@exchange.boeing.com

IQ IN YOUR INBOX

Sign up at Boeing.com/IQ



**SCAN CAM HERE,
BOOST YOUR IQ!**
Boeing.com/IQ

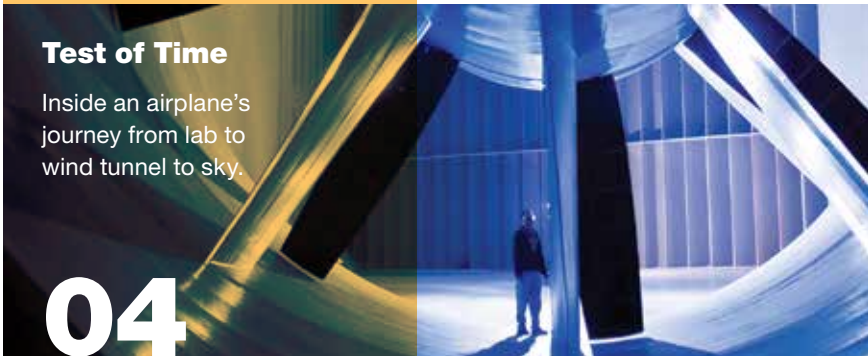

Test of Time

Inside an airplane's journey from lab to wind tunnel to sky.

04

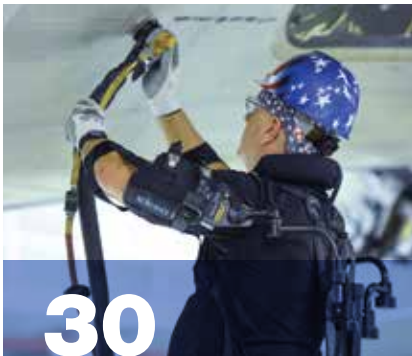

30

Suit Up for Safety

Exoskeleton vest reduces strains and sprains while increasing quality.



48

Machines Can See, Hear and Learn – From Humans

Human-centric machine learning in India.

16 | Safety as a Culture: Q&A With Mike Delaney

Boeing's Chief Aerospace Safety Officer offers an inside look.

22 | Safety on Call

Behind the scenes with air safety investigators.

36 | Fast Forward

Get up to speed with Boeing's chief scientist of hypersonics.

42 | Genes in Space

Astronaut safety may fight cancer on Earth.

47 | TopShot: Mirror Image

The Boeing 2021 ecoDemonstrator includes a surprise.

56 | The Space Between

The origin story of a proprietary journal.

62 | Insight: Quantum Computing

How to turn promise into value.

71 | History of Safety

70-year-old document spells it out.

76 | PatentPower: Weight Watcher

Methods and apparatus to measure mass in low gravity environments.

78 | Out&About: Inspiring the Future of Flight

Sky's the limit for students in Poland and India.

82 | TopShot: High on the Warthog

See an A-10C Thunderbolt II on the runway in St. Louis.



Foundational Safety

“Can we fly?” is an important question. But the crucial question is “Can we fly safely?”

Since the earliest days of Pacific Aero Products Co., which would eventually become The Boeing Company, safety has been the foundation — safety in the workplace and safety in the sky. Aerospace is viable only if it moves people safely and ensures the well-being of those who design, build, support and operate our products and services.

We are not perfect, but we are committed to improving safety throughout our industry, and that commitment appears on every page of this edition of Innovation Quarterly.

From lab to wind tunnel to sky, our teams test and evaluate, every step of the way. Each product we produce is poked, prodded and pushed beyond the limits to ensure it can withstand the pressures of the real world.

When an incident or accident does happen, our teams of air safety investigators and technical experts relentlessly pursue the cause. As a result of their work, aerospace safety innovation is often adopted from that point forward.

Safety on the factory floor appears in the form of a superhero-like exoskeleton device. Arms and shoulders

of those who perform overhead work are better supported, resulting in enhanced safety of the team members and the product.

Our responsibility continues a companywide charge. We find a 70-year-old safety document that lines up with the language of today and shows our current accountability is built on decades of diligence.

And hovering over it all is our Safety Management System that is nurtured by a positive safety culture and a just culture — all of which directly affect the safety of our products and services.

We have an understood agreement with our team members, our customers and the flying public: Safety is where it starts. **IQ**

CARLA DAVIS-MADGETT
Vice President,
Environment, Health & Safety

MICHAEL P. DELANEY
Chief Aerospace Safety Officer
Senior Vice President,
Global Aerospace Safety

Test of Time

Inside an airplane's journey from lab to wind tunnel to sky

Step by step through Boeing's testing process

BY KATE EVERSON, BOEING WRITER

The sounds of seat belts buckling say it's time to fly. Chief pilot Jennifer Henderson and co-pilot Heather Ross run through safety checks as they listen through their headphones for permission to take off. From their front-row seats on the flight deck of a 737-10, they aim to demonstrate what this new airplane can do in the most extreme conditions.

The flight is a beginning, at the front end of the airplane's flight-test program. At the same time, it is also near the end of a rigorous testing process that started far earlier. Test and verification are crucial to developing new airplanes, both new models and derivatives of existing models. Every new airplane that Boeing develops undergoes lab, ground and flight testing to make sure it meets all safety and operational requirements. The U.S. Federal Aviation Administration (FAA) validates the information gathered during the process.

SWITCHING INTO GEAR

Boeing test pilot Jennifer Henderson in the flight deck of a 737-10.

PHOTO: DAVE SIZER/BOEING





ALMOST THERE

By the time an airplane gets to the experimental stage on the tarmac, it's nearly ready to fly. But thousands of people and hours of effort and testing paved the way to the runway.

PHOTO: MICHAEL KING/BOEING



VIRTUALLY A BREEZE

Digital imagery depicts air moving across wings.

PHOTO: BOEING



MINI MAX

A scale 737 MAX model undergoes wind tunnel testing. Models must be exact — the slightest roughness has to be sanded down, as the scales at the facility have the ability to measure the model's weight with pinpoint precision.

PHOTO: BOEING

“Every test we run — from the lab to the sky — is paramount to the safety and quality of our products,” said Wayne Tygert, Boeing Test & Evaluation vice president and chief engineer. **“We carry a One Boeing spirit and a commitment to safety through each step, from early concept development, system integration, production testing, all the way to delivery and in-service support.”**

Laboratory Testing

From its early creation, every Boeing airplane model endures testing in several laboratory environments, including wind tunnels, icing tunnels, indoor and outdoor antenna and radio-frequency scattering ranges, lightning labs, propulsion labs, acoustic labs, vibration labs, systems labs and simulation labs.

“People think we just test the finished product, but we also help enhance the finished product,” said Frederic Lambert, senior manager of Systems Laboratories.

Once the development team has an idea of the new airplane's configuration, Boeing's Aero, Noise and Propulsion teams perform wind tunnel testing on scale models of the airplane or its components, with various sensors embedded in the model to measure how the designs interact within various airflow or maneuvering conditions as well as to gather data on the product's aerodynamic, noise and propulsion performance.

AIR APPARENT

Wind tunnels such as this one in Philadelphia test fixed- and rotary-wing aircraft models, half models, powered models, non-aeronautical vehicles and structures, and some full-scale vehicles. The fan is 39 feet (12 meters) in diameter.

PHOTO: BOEING

“People think we just test the finished product, but we also help enhance the finished product.”

FREDERIC LAMBERT,
SENIOR MANAGER OF SYSTEMS
LABORATORIES



Test teams work in both simulated and physical environments to verify that the components in a new product's systems work together reliably and as designed.



Structural Testing

Several structural tests measure the airplane's overall integrity. Materials testing confirms strength and durability not only of the materials themselves but also of the joints and seams holding together pieces of the airplane, while static testing uses weights and measuring devices to assess and document the airplane's response to critical loading conditions.

Fatigue testing puts the airplane through the repetitive stresses of two to three lifetimes by simulating takeoffs, climbs, cruises, descents and landings to confirm the durability and damage-tolerance characteristics of the primary airframe structure and to demonstrate the design's effectiveness at preventing the possibility of damage over time. The process also verifies the design service objective of the airplane and the proposed inspection, maintenance and repair procedures.

BRING THE NOISE

Early in the design process, 777X window panels are evaluated in a lab to allow engineers to make subtle changes that will minimize noise in the cabin.

PHOTO: BOEING

Simulation Testing

Simulation testing tracks an airplane's capabilities through its development and can help supplement and precede flight testing. The Systems lab can log the equivalent of 45 years of virtual flight-test hours in five weeks, allowing the lab to test an airplane's software in myriad conditions, including crosswinds, varying distribution of weight and different amounts of fuel.

Simulators come in handy at the features level too, particularly when evaluating a new development. For example, when evaluating the addition of touch-screen displays to the flight deck, the 777X team needed to make sure a pilot could accurately operate the displays in extreme conditions.

"They strapped me in the motion cab with some rudimentary touch screens," Lambert said, explaining that he had to touch an X wherever it showed up on the screen as they shook the cab to simulate severe turbulence. "The concept of the touch screen was validated in that facility because we learned it's not hard to manipulate, even when shaking a lot."

Once the hardware meets software, Systems Integration Lab test teams work in both simulated and physical environments to verify that the components in a new product's systems work together reliably and as designed — as one integrated system within the product.

Not all ground tests take place inside a lab, simulator or tunnel. The Boeing Test & Evaluation Flight Emulation Test System van hooks up to a completed airplane as it sits on the tarmac. The equipment inside the van links with the airplane's computer and, as Lambert described, allows the team to simulate flight conditions by removing all indicators that the airplane is still on the ground.

"We can simulate the speed, altitude, position and landing gear from there," Lambert said. "That way when we begin flight testing, we've 'flown' the plane before."

Flight Testing

Once the appropriate ground tests are complete — and as others continue — the teams involved in the airplane's development perform first-flight readiness reviews that ensure all requirements are met and the airplane is ready to fly safely. The teams use Boeing's Seek, Speak & Listen principles to guarantee transparency and honesty, and only if everyone involved is satisfied with the ground-test results does the airplane take flight for developmental testing and eventual certification tests.

There are three high-level milestones that Boeing uses to mark progress in flight test. The first, initial airworthiness, explores the flight envelope — the airplane's operating parameters such as speed and altitude limits.

FREEZE FRAME

A B1-B Lancer at Eglin Air Force Base in Florida in 1986 undergoes arctic testing to simulate extreme conditions. A legacy of testing ensures expertise is passed on over decades.

PHOTO: U.S. NATIONAL ARCHIVES

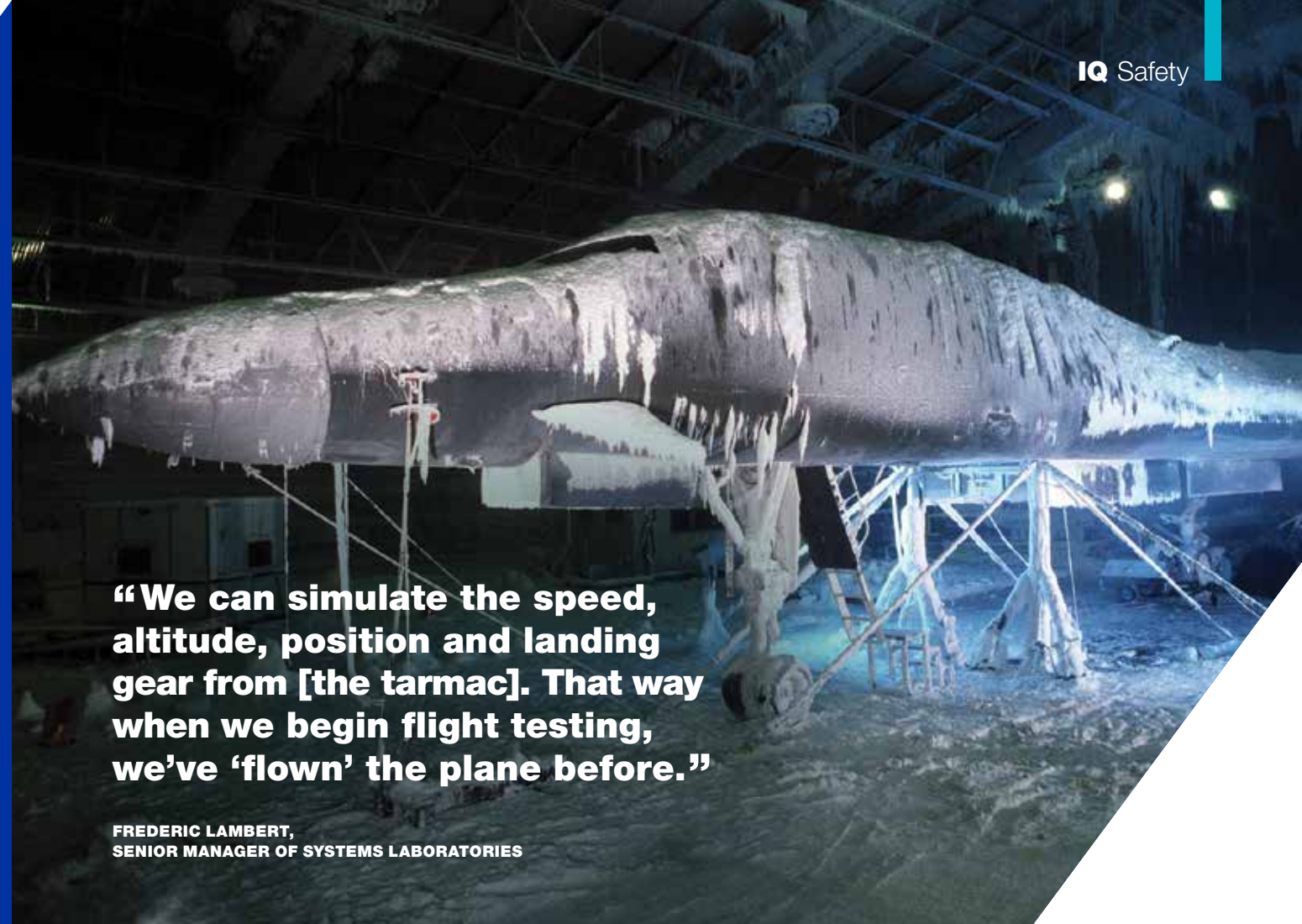

"We can simulate the speed, altitude, position and landing gear from [the tarmac]. That way when we begin flight testing, we've 'flown' the plane before."

**FREDERIC LAMBERT,
SENIOR MANAGER OF SYSTEMS LABORATORIES**

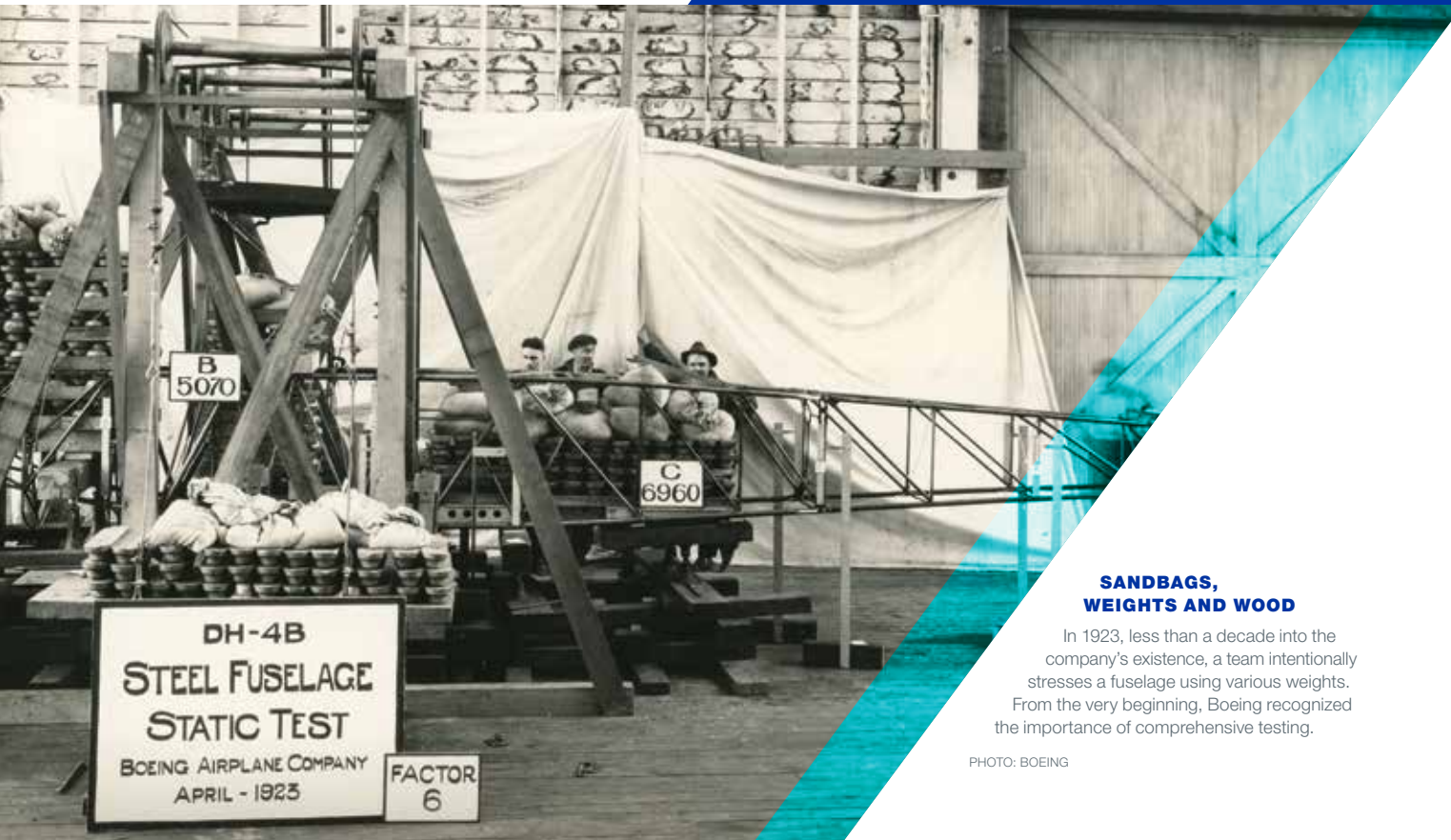

SANDBAGS, WEIGHTS AND WOOD

In 1923, less than a decade into the company's existence, a team intentionally stresses a fuselage using various weights. From the very beginning, Boeing recognized the importance of comprehensive testing.

PHOTO: BOEING



WATER WEIGHT

Engineers can quickly fill tanks with water to gauge this 737-10's response to shifting weight.

PHOTO: MICHAEL KING/BOEING

Once initial airworthiness is demonstrated, the second milestone is reached when more Boeing test personnel are permitted to fly aboard the airplane, which allows for more extensive testing that requires flying farther distances and monitoring more sensor readings.

Instead of rows of seats, flight-test cabins are filled with workstations and sensor equipment. A crew of six to 20 engineers — plus the two pilots — stays connected over headsets as they monitor the data while putting the airplane through takeoff, flight and landing.

“We have access to everything the flight deck sees, including when the airplane passes a landmark like Mount St. Helens or a glacier,” said flight test engineer Laura Garcia-Schmitz. “It’s such a unique experience being up there with all that information, instead of just being told you’ll get to your destination in three hours.”

This is also an opportunity to validate what Boeing airplanes are built to do in the most extreme situations.

“We have access to everything the flight deck sees, including when the airplane passes a landmark like Mount St. Helens or a glacier. It’s such a unique experience being up there with all that information, instead of just being told you’ll get to your destination in three hours.”

**LAURA GARCIA-SCHMITZ,
FLIGHT TEST ENGINEER**

DIGITAL TRAY TABLES

During flight testing, engineers assigned specific tasks observe and record data while in the air at individual stations on this 737-10.

PHOTO: MICHAEL KING/BOEING

“We look at the data and graphs and say, ‘You can operate the airplane within these limits.’ How do we know the airplane can operate safely in those limits? We test them outside of those limits.”

**QUEONDRA HENDRIX,
ENGINEER, BOEING ENGINEERING
CAREER FOUNDATION PROGRAM**

“We look at the data and graphs and say, ‘You can operate the airplane within these limits,’” said Queondra Hendrix, an engineer in the Boeing Engineering Career Foundation Program who currently works with the flight-test team. “How do we know the airplane can operate safely in those limits? We test them outside of those limits,” on top of designing to requirements, demonstrating it through tests and analyzing the data to confirm the airplane’s performance capabilities.

Safety is the most important aspect of the flight-test process. Hendrix said every test has a designated cabin safety expert who leads preflight briefings similar to that of commercial flight attendants. Test pilots use checklists when preparing for flights to mitigate the risk of human error, and only required crew members are allowed on board on any given flight.

Once an airplane is deemed mature enough and all required documentation has been thoroughly reviewed, the FAA grants Type Inspection Authorization, the third milestone. This allows FAA personnel on board for certification testing, which puts the airplane through a rigorous program of tests: stalls, water sprays, crosswinds and minimum speeds, to name a few.

Flying in scenarios that most pilots would never experience gives Boeing, the FAA and other regulators a full understanding of the airplane in normal and abnormal circumstances. By the end of the program, the team, regulators and customers know that the airplane can be safely operated in revenue service.

“Every day when I come into work, I feel a sense of purpose,” Garcia-Schmitz said. “I am directly responsible for an airplane being allowed to fly.” **IQ**

ALL-TIME TEAM

(From left) Colette Posse, Laura Garcia-Schmitz, Bailey Bonaci, Lauren Meyer, Queondra Hendrix, Sarah Price, Chelsea Katan, Janet Prentice, Jennifer Henderson, Patty Graves, Heather Ross and Rachel Soderberg gather around a banner created by colleague Ankita Sharma. It says, “Women Aloft Flight Test MAX 10.”

Photo taken in accordance with local COVID-19 pandemic safeguards.
PHOTO: DUNES WIJAYRATNE/BOEING



Women Aloft: Historic Flight Test Crew

In October 2021, sky-watchers in Washington’s Puget Sound region may have witnessed history without knowing it. A 737-10 soared above — not unusual, as it was performing a routine developmental flight test. But unseen from the ground was something special: The ground and onboard crew was made up entirely of women.

“It’s so much more special to be one of many than it is to be the only one,” flight-test engineering analyst Chelsea Katan said. “That was something that was really unique about this flight, instead of being one standout woman. It meant a lot to everyone on the crew.”

Katan says the team is the first all-woman crew on record to conduct a flight test at Boeing. September and October 737-10 flight-test crew demographics show that apart from the Oct. 20 flight, women made up no more than a quarter of each crew on each flight test.

The developmental test — which they dubbed the “Women Aloft Flight Test” — was part of the 737-10’s certification process, with the crew responsible for gathering initial stability and control data that will be used to certify the aircraft for commercial use. Everyone on board was responsible for monitoring and recording information during flight.

Flown by chief pilot Jennifer Henderson and co-pilot Heather Ross, test aircraft 1G001 flew with a crew including Rachel Soderberg, test director; Janet Prentice, flight analyst; Katan and Sarah Price, flight-test engineering analysts; Laura Garcia-Schmitz and Bailey Bonaci, weights and cabin safety; Lauren Meyer and Queondra Hendrix, instrumentation; and Colette Posse and Patty Graves, stability and control engineering.

The flight test was also supported by Annemarie Phandinh, Gabriela Gutierrez-Duran, Hilary Fiorentino and Ankita Sharma on the ground, with Ashley Abril, Casey Burt and Yoslin Herrera performing follow-up and greater Flight Test team diversity and inclusion efforts.

Katan, Phandinh and Sharma ran a debrief conversation a month later to discuss how the engineers who ran the Women Aloft Flight Test felt the experience differed from working with predominately male crews.

Sharma said that after experiencing several microaggressions as a female engineer — including being the only one asked to provide her qualifications in a pre-test briefing — and hearing from other women that they sometimes hesitate to speak

up and feel ignored or underestimated, this flight-test experience felt more inviting and collaborative.

“This is the first step to change,” Sharma said. “The Women Aloft Flight Test wouldn’t have been possible 10 years ago — it’s a symbol of progress, and we will keep doing better.”



Q

A

&

With Mike Delaney

Safety as a culture

Boeing's Chief Aerospace Safety Officer offers an inside look

Aerospace engineer Michael P. Delaney is responsible for strengthening the safety practices and culture at Boeing and developing the company's comprehensive Global Aviation Safety strategy.

PHOTO: BOEING

IQ: How does a positive safety culture activate Boeing's Safety Management System (SMS) – and advance the safety of products and services in particular?



MD: SMS really came out of the airline side of our business. It's a top-down, organizationwide approach to managing safety risk, and it ensures you have effective risk controls that you can take action on. So in that context of the SMS, how do you make it successful?

Underlying that is a positive safety culture that has several critical elements. You want the organization to be **informed** and knowledgeable about the technical factors, the environmental factors, the changes going on.

You want the organization to be **flexible** in the way it can deal with issues as they come up and also make decisions that are substantive and take action.

You also want a **learning** organization that draws conclusions on safety that affect the outcome.

Then there's the **reporting** piece, what we call in-house "speak up." People can voluntarily raise safety issues in a way that the organization will respond and learn from.

And the critical aspect of that is the concept of a **just culture**.

It's a balance between, on one extreme, a highly punitive culture and, on the other extreme, a culture that has no consequences. And what you really want to do is define where the line is. When you're on the one side of the line, the organization's response is to learn and adapt and get better and stronger and safer.

And if you cross the line, then there is a consistent behavior of taking action. And you really don't want to blend those, because that becomes critical to enable people to want to speak up, to want to learn, to understand the risks and make flexible responses.

You want the organization to be flexible in the way it can deal with issues as they come up and also make decisions that are substantive and take action.

Positive Safety Culture



A positive safety culture is a key enabler for SMS to be successful.

GRAPHIC: BOEING

IQ: Diving into details — what is Boeing doing to demonstrate a commitment to that positive safety culture? In other words, what's changing?



MD: We stepped up voluntarily into this SMS in light of some of the incidents that have happened in the company. We will always still have a compliance- and a conformance-based requirement of our regulation. But we're now adding this additional Safety Management System piece, which will go with our quality management and compliance systems to enable us to unlock further safety in the operator.

Historically, we worked in a compliant and conforming environment to deliver safe products. And we always worked in a risk environment in continued airworthiness. But in this case now, by having an SMS and a positive safety culture that aligns with the airlines and industry, if there's something that the airlines see as a risk, it may in fact be the OEMs (original equipment manufacturers) that can improve safety.

And we're starting to see these relationships through this common language and behavior that enable us to talk with our airlines and take action that will improve the safety of the flying public in the commercial space based on actions we take in the OEM space.

It is a collective effort by our team to understand this positive safety culture and to think about the actions and controls we have that can impact the safety of the fleet.

**SCAN CAM HERE,
BOOST YOUR IQ!**

Audio: More from Mike on safety inside Boeing.



IQ: All of the above, it's only relevant if the people are on board. In what ways can employees themselves embody that positive safety culture and work together to make it happen?



MD: When you say employees, what I hear is “everybody who works for The Boeing Company.” Sometimes when we hear employees, we think engineers or mechanics. We don't think about management, executives. To me, everybody, from Dave Calhoun (Boeing CEO) down to myself are employees, right?

It is a collective effort by our team to understand this positive safety culture and to think about the actions and controls we have that can impact the safety of the fleet.

And today we're leading through commercial. But clearly this has implications to our defense and services sides. Having our employees understand this is something we get to do to make the flying public better, to make The Boeing Company better. These are not things we're doing to our employees. These are things we are doing to improve the safety of the people who fly and use our products.

IQ: Historically, the industry has a strong safety record. And the SMS journey is intended to further enhance that safety across the entire industry. So where is Boeing right now on that SMS journey?



MD: The OEMs are just starting this journey. The good news is that we have people we can look at. Externally, the airlines have been on this journey for quite some time. Some of our customers use the same language around just culture, SMS and positive safety culture.

And then even better news: We have a couple locations in Boeing that have mature SMS, positive safety cultures and just cultures. And those look very similar to some of our big customers.

One of them is in Boeing Defence UK. We have been working with them and benchmarking them, using them as an example. We are going to learn from our own team, and we are going to steal shamelessly from our customers that are already down the line on this journey and really try to leverage it and connect it — connect our SMS and our risk register to our customers and to the industries and ideally to the other big players in the industrial space. That's how we will move the needle on safety. **IQ**

Safety on call

Behind the scenes with air safety investigators

BY MEGAN HILFER AND ED MUIR, BOEING WRITERS

Boeing teams inspire lasting aviation safety innovation

Eric East got the late-morning call about a Boeing cargo jet.

The National Transportation Safety Board (NTSB) said the airplane had gone down in a swampy area near Houston. Within 24 hours, East and a team of other Boeing technical experts from Washington state were on scene to provide assistance to the NTSB.

“Nothing is more important than the safety of everyone who flies on our airplanes,” said East, a Boeing Associate Technical Fellow and senior air safety investigator. “From the moment we get the call, the devastating impact of these accidents is always on our minds.”



ON SITE

Alongside NTSB members and a Texas game warden, Boeing air safety investigator Eric East (right) searches near Houston for recorders from a cargo jet crash. Pinger locator equipment enables him to listen for the underwater locator beacons.

PHOTO: NTSB



PHOTO: BOEING

They quickly went to work in an airboat and began to search the muddy waters for the flight data recorder and cockpit voice recorder underwater locator beacons in the wreckage field around the crash scene. More technical experts joined the investigation. Thousands of pieces of debris were recovered and reconstructed by the investigation team over the next several months.

“It’s more than recovering physical pieces of the airplane. Investigators take a holistic approach to help determine exactly what happened,” East said. The Boeing Air Safety Investigation (ASI) team and the Boeing technical experts who support it play a critical role to advance aviation safety.

When an incident or accident occurs involving a Boeing airplane anywhere in the world, Boeing’s ASI team is always ready to respond.

“It’s more than recovering physical pieces of the airplane. Investigators take a holistic approach to help determine exactly what happened.”

**ERIC EAST,
BOEING SENIOR AIR
SAFETY INVESTIGATOR**

Poised and Ready

Following an airplane accident or incident, an investigation led by the relevant country’s accident investigation authority will likely be launched. Boeing stands ready to provide technical advisers to the NTSB, the U.S. agency that leads domestic investigations and represents the state (or country) of manufacture and design when a Boeing airplane is involved in an incident or accident elsewhere.

The NTSB is responsible for gathering and analyzing evidence to determine the cause and for issuing safety recommendations. The agency works with the airplane, engine and other component manufacturers who provide the technical expertise related to the design and operation of their products.

Under the protocols governed by the International Civil Aviation Organization, Boeing’s support of an investigation focuses on data and technical expertise, including information specific to the airplane, such as its systems, controls and operating procedures, and access to resources, such as labs, specialized equipment and technical experts.

The data gathered helps ensure the continued airworthiness of the existing fleet by identifying if there are potential product safety issues. However, the investigations may also reveal findings that help inform future designs and safety enhancements while uncovering lessons learned that benefit the broader aviation industry.

A government investigation can take anywhere from months to a few years to complete, culminating with a final report that provides context, identifies contributing factors and often provides recommendations to improve safety.

The ultimate mission for all: to determine cause, prevent recurrence and make improvements.

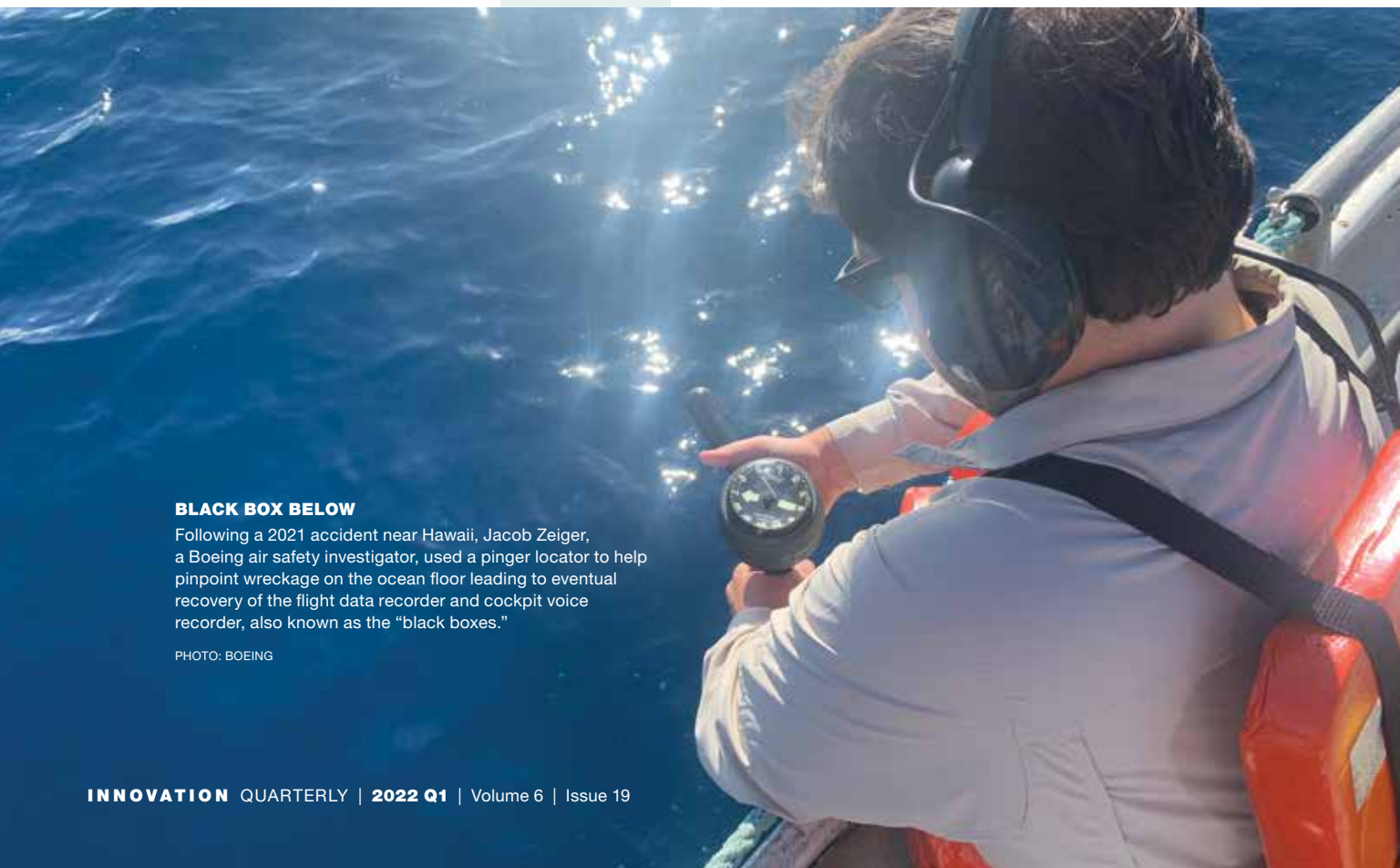

BLACK BOX BELOW

Following a 2021 accident near Hawaii, Jacob Zeiger, a Boeing air safety investigator, used a pinger locator to help pinpoint wreckage on the ocean floor leading to eventual recovery of the flight data recorder and cockpit voice recorder, also known as the “black boxes.”

PHOTO: BOEING

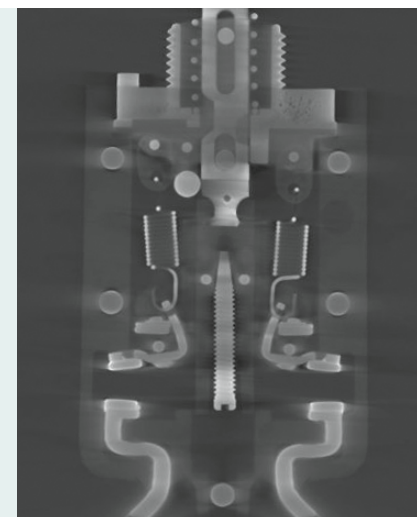

PRESERVATION OF EVIDENCE

Boeing assists investigation authorities in examination of components such as this circuit breaker. The Boeing Equipment Quality Analysis Lab uses nondestructive techniques such as computed tomography scanning and digital X-rays, capturing perishable evidence.

PHOTO: BOEING

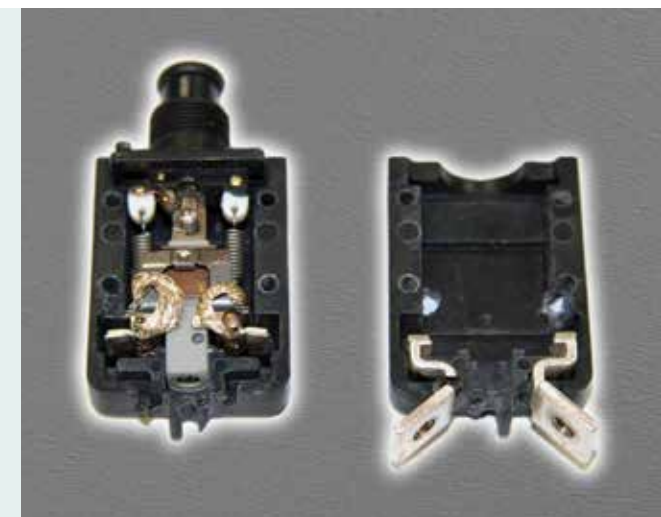

VERIFICATION

Highly skilled Boeing personnel can help identify potential anomalies before disassembly or sectioning of components for evidence collection, providing further insight and focus to the investigation.

PHOTO: BOEING



PHOTO: BOEING

Team Tasks

As the airplane manufacturer, Boeing dedicates technical expertise and its unique resources and capabilities to aid from the initial wreckage recovery through the entire investigation. ASI leads the Boeing technical team comprising experts who bring their deep knowledge and experience in the design, build, test, certification and in-service support of Boeing products and services:

Jay Shoji, a Boeing Associate Technical Fellow, is part of a small group of structural analysis engineers who may be called upon by ASI to help identify aircraft parts on scene.

Shoji may be required to travel to an accident site as quickly as possible and has a “go bag” packed in case of emergency.

Once Shoji and others gather as many aircraft parts as possible, he sometimes works with the NTSB team to “reconstruct” the airplane. The investigative team would lay out the debris in a nearby warehouse or other space to try to piece it together like a jigsaw puzzle; this process can take weeks.

The team looks for signs of damage on the debris. Are the aircraft pieces blackened, which may point to a fire or explosion? How expansive is the debris field? In an accident where the wreckage is unrecoverable, would the maintenance logs and other records indicate something meaningful about the aircraft’s history?

“Most accidents have no structural cause,” Shoji said. “So most often, the investigation team essentially performs a forensic investigation, piecing together physical clues to determine the sequence of events. However, if there is an indication of a potential structures contribution to the accident, we’ll look for structural anomalies, for clues to what may have caused the accident.”

RECONSTRUCTION

This digital reconstruction of a fuselage was created by Boeing structures and liaison engineers for an NTSB investigation. It can help determine if structural anomalies were present and whether the airplane was intact during the accident as well as reveal the overall accident sequence.

GRAPHIC: BOEING

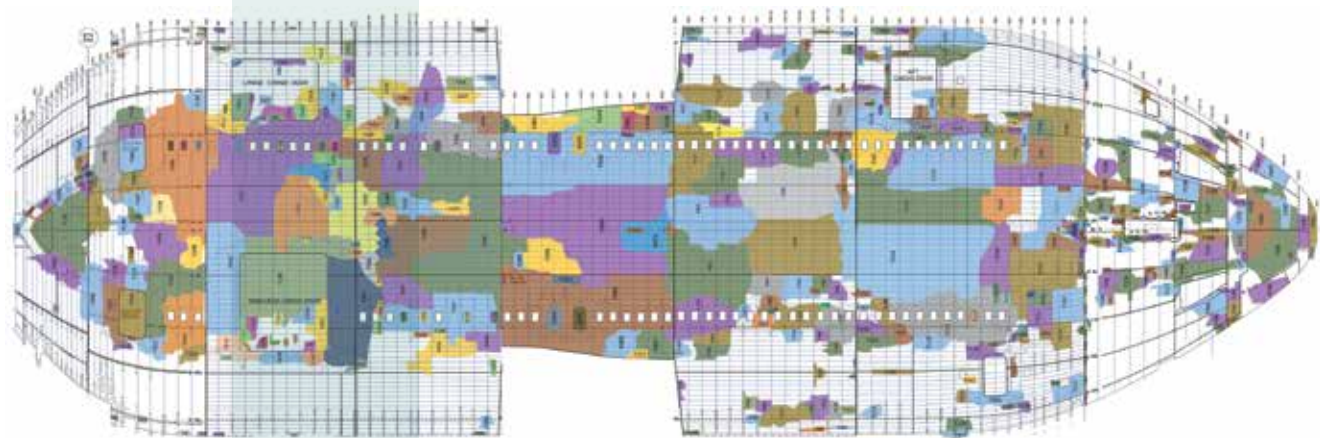

SIMULATING SAFETY

Using actual flight data, technical experts can run flight scenarios using Boeing’s engineering flight simulators to provide investigators insight into both airplane performance and human factors.

PHOTO: BOB FERGUSON/BOEING



PHOTO: BOEING

Scott Lunde works in the Aerodynamics Stability & Control Post-Certification Support group. The group analyzes flight recorder data to help confirm expected airplane performance and identify contributing factors to in-service incidents or accidents on Boeing commercial airplanes.

Once his team receives the data from an accident investigation, members create working plots, analyze the data and coordinate with other Boeing subject matter experts to help understand the data. They then share this analysis with ASI and the NTSB to support the ongoing investigation, all with the goal of identifying potential causes and contributing factors.

“Our team has developed a number of analysis methods over the past 25-plus years that help us to understand the event,” Lunde said. “These include data plotting techniques, methods of calculating information not captured by the recorder, the use of desktop simulation to evaluate expected airplane performance, animations to visualize the airplane, and piloted simulator cab sessions to investigate event timing and crew resource management.”

Vic Riley, a human factors engineer and Boeing Associate Technical Fellow, supports the investigation by helping analyze flight deck and other data to determine how pilots behaved in the time leading up to an incident.

He asks key questions: What were their expectations and habits, and how could those have contributed to the way they reacted? What did they pay attention to? How did they communicate with each other? In short, did pilots act as they would be expected to under the circumstances? And if they didn’t, why not?

“The pilot is the most complex and least deterministic part of the airplane,” said Riley.



PHOTO: BOEING



PHOTO: BOEING

Steve Chisholm is a mechanical and structural functional chief engineer. When Chisholm was a Boeing Associate Technical Fellow, he consulted with ASI on several airplane accidents. Among those, he spent the most time working on a 747 that went down in the waters off Long Island, New York, in 1996.

In the year following that crash, Chisholm spent five to six months in New York, working seven-day weeks, 14- to 16-hour days, helping piece together what happened. Among issues unique to that investigation, the FBI and CIA personnel on scene did not allow pictures to be taken while they investigated whether the crash was the result of a crime, so Chisholm drew sketches of the debris field.

As Chisholm and other investigators physically reconstructed the aircraft at a hangar on Long Island, they attempted to solve the riddle of sequencing — the potential order of how things happened — which was a new way to approach crash investigations.

He and his team aimed to determine the direction of a fracture or source of fire on a wing or segment of fuselage. After establishing the direction, the team worked backward toward the source of the fracture, which eventually led them to an issue with the center fuel tank.

Chisholm also helped propose and implement process improvements in investigations. For instance, ASI team members now take blood-borne pathogen training courses, which used to be available only to first responders. Chisholm says more mental health services are provided for investigators now as well.

“We realize what we’re doing is very important,” Chisholm said. “We hope our work means a similar accident doesn’t happen again.” **IQ**

“We realize what we’re doing is very important. We hope our work means a similar accident doesn’t happen again.”

**STEVE CHISHOLM,
BOEING MECHANICAL AND
STRUCTURAL FUNCTIONAL
CHIEF ENGINEER**

Lasting Change

Following the tragedy of airplane accidents, regulators and other officials often reexamine protocols and safety regulations, which can lead to important safety changes. Due to the international and domestic protocols in place, the company is limited as to what it can share publicly during an investigation. One exception is when product safety issues are uncovered during the course of an investigation that are important to share with the entire fleet for continued airworthiness.

Here are several examples of investigations that helped inspire aviation safety innovation and shape procedural and technology improvements in place today:

- **March 27, 1977, 5:06 p.m.**
**Western European Time,
Tenerife Airport, Canary Islands**
Miscommunication between air traffic control and the flight deck resulted in forming the standardized communication practices now used worldwide.
- **Aug. 12, 1985, 6:56 p.m.**
**Japan Standard Time,
Mount Osutaka, Japan**
Catastrophic depressurization at 24,000 feet drove critical changes in airplane design and repair protocols.
- **July 19, 1989, 3:16 p.m.**
**Central Daylight Time,
Sioux City, Iowa**
In-flight disintegration of an engine fan disk led to extensive modifications of hydraulic control systems.
- **Dec. 20, 1995, 9:41 p.m.**
**Eastern Standard Time,
Cali, Colombia**
A mountainside collision resulted in enhanced terrain-awareness warning systems found on all commercial airplanes today.
- **Jan. 31, 2000, 4:19 p.m.**
**Pacific Standard Time,
north of Anacapa Island, California**
In-flight failure of a horizontal stabilizer assembly led to revised maintenance-testing procedures and increased regulatory oversight of maintenance.

What’s Next

Aviation safety is a journey of continuous improvement.

Each accident is tragic and an opportunity to evaluate if there are steps we can take to enhance safety. We will always remember those who lost their lives as well as their families. We will honor them by holding close the hard lessons learned from our journey. We have and will continue to institute lasting changes that continue to increase the level of safety in air travel.

For Boeing, that journey is illustrated by steady progress with the implementation of an enterprise Safety Management System (SMS). The SMS is an industry-proven approach to managing safety risk and ensuring the effectiveness of safety risk controls.

Boeing’s SMS will incorporate data from regulators; customers; employee reporting; and existing production, compliance, quality and safety processes. Ultimately, the intent is to bring the right data into the right forums to make data-driven, risk-based decisions that help prevent accidents and protect people.

As part of a robust SMS in place, Boeing needs a strong ASI team. And investigators such as Eric East and his colleagues are always ready for the call.

Bionics allow teammates to suit up for safety

Exoskeleton vest reduces strains and sprains while increasing quality

Jason Hill, a Boeing Salt Lake airplane mechanic by day and avid hockey player in his off-hours, truly appreciates the protection the right safety gear provides both on the job and in the rink.

“I suit up for hockey. I wear my helmet. I wear all my pads so that I don’t get injured,” said Hill. “And I do the same thing when I come to Boeing.”

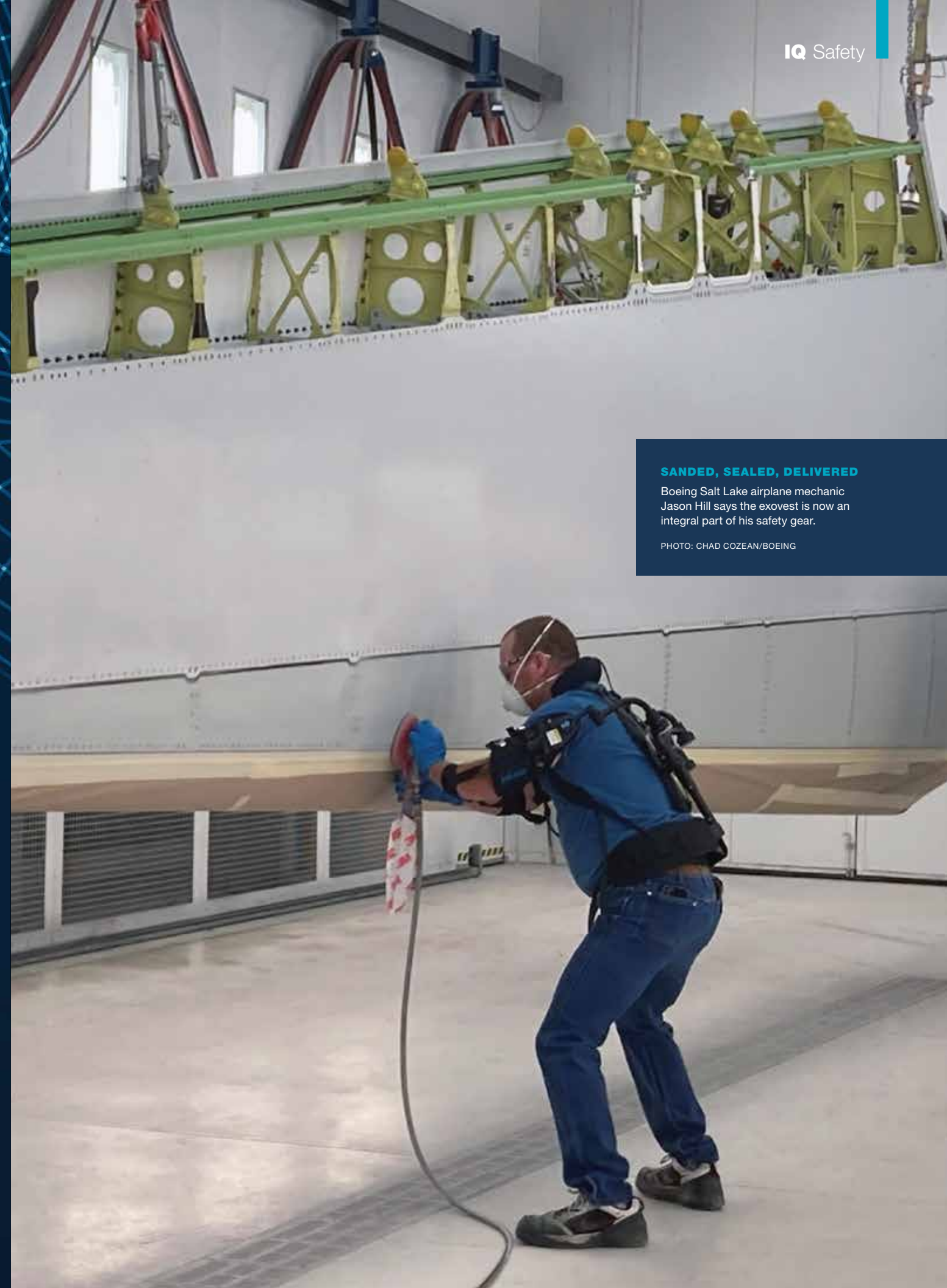

SANDED, SEALED, DELIVERED

Boeing Salt Lake airplane mechanic Jason Hill says the exovest is now an integral part of his safety gear.

PHOTO: CHAD COZEAN/BOEING

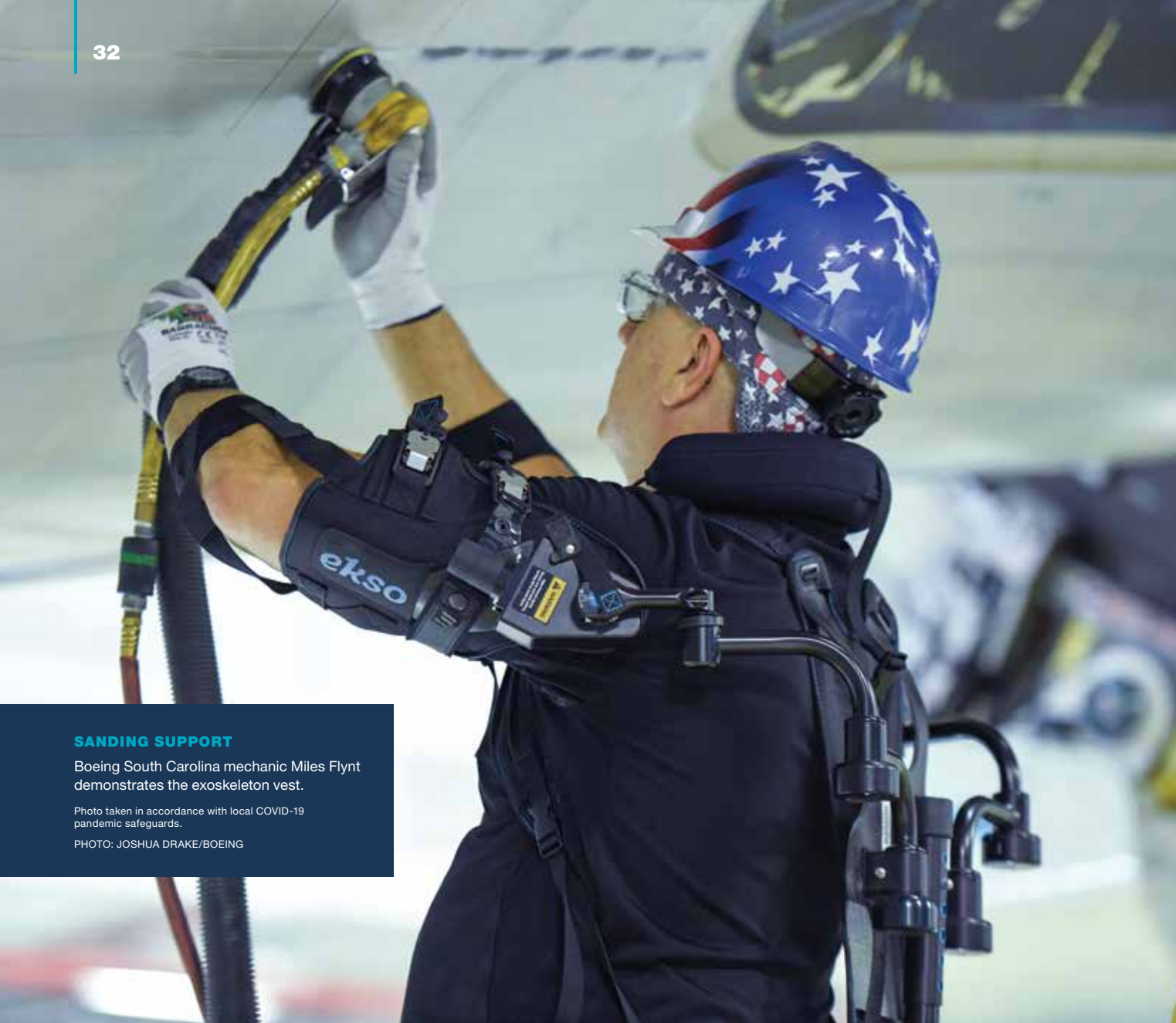

SANDING SUPPORT

Boeing South Carolina mechanic Miles Flynt demonstrates the exoskeleton vest.

Photo taken in accordance with local COVID-19 pandemic safeguards.

PHOTO: JOSHUA DRAKE/BOEING



“It feels like someone’s behind me holding up my arms.”

MILES FLYNT, BOEING SOUTH CAROLINA MECHANIC

Thanks to a new bionic exoskeleton vest, teammates at locations across Boeing are getting a welcome boost when performing prolonged overhead work.

Sanding, sealing and painting the 787 Dreamliner horizontal stabilizer requires Hill to spend significant time working with his arms stretched above his head — work that once put additional strain on his shoulders, forearms and elbows.

Thanks to a new bionic exoskeleton vest, Hill and teammates at locations across Boeing are getting a welcome boost when performing prolonged overhead work.

In Boeing’s commercial division, the exoskeleton vest is in use or planned for use as personal protective equipment in the 737, 767, 777 and 787 Dreamliner programs. As for the company’s defense products, the device will assist team members working on vertical lift aircraft including the V-22 and H-47 and on fighter jets including the F-15 and F/A-18, as well as P-8 maritime

patrol aircraft, MQ-25 unmanned aerial refueling systems and VC-25B presidential aircraft (Air Force One).

Teams at a number of Boeing sites have tested the vest since 2018. It is rolling out as an innovative enterprise standard tool designed to lessen the pressure mechanics bear as they work repetitive jobs at chest level and above.

“It feels like someone’s behind me holding up my arms,” said Miles Flynt, a Boeing South Carolina mechanic.

“When you activate the vest, it’s somewhere between 5 to 18 pounds (2 to 8 kilograms) offloaded from the wearer,” said Dr. Christopher Reid, a Boeing engineer and Associate Technical Fellow who specializes in ergonomics and wearable technology. “It reduces the stress on the shoulders and ultimately reduces injuries.”

Resembling a high-tech comic book character’s armor, the spring-based mechanism is worn much like a backpack. It employs a system of straps and mechanical arms, supporting users’ shoulders as they perform overhead work such as drilling.

“The first time wearing it, I felt kind of silly,” said 767 mechanic Jacob Case, who likened the device to something straight out of science fiction. “But I noticed my hands and arms being above my head not feeling so heavy, and I really noticed a big difference in my shoulder blades.

“By the end of the work day, I noticed that it reduced the amount of fatigue for sure.”

THANKS FOR THE LIFT

Working on a 767 in Everett, Washington, mechanic Jason Turner is much more comfortable thanks to a shoulder support exoskeleton.

PAUL CHRISTIAN GORDON/BOEING

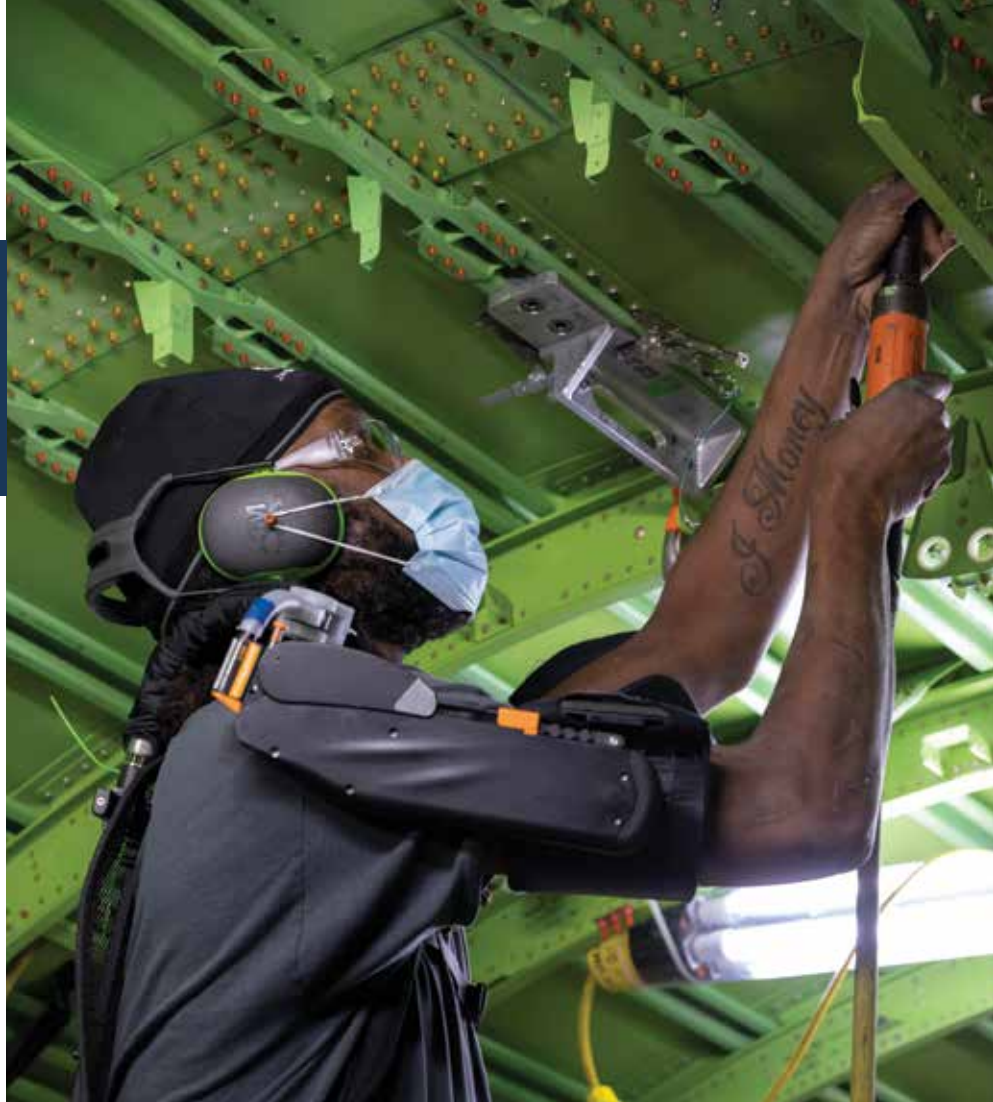

Futuristic as it may seem, the vest is positively affecting safety today.

“Where else can you make world-class aerospace products and feel like a superhero at the same time?” said Paul Wright from Boeing’s Chief Aerospace Safety Office. “These vests keep our teammates injury-free and allow them to go home feeling great. Many areas that have implemented them continue to see zero injuries a year later.”

Though deployed in 2021, exoskeleton technology has been evaluated and tested for several years with Boeing Research & Technology and Environment, Health & Safety. **IQ**

“These vests keep our teammates injury-free and allow them to go home feeling great.”

**PAUL WRIGHT,
CHIEF AEROSPACE
SAFETY OFFICE**



**SCAN CAM HERE,
BOOST YOUR IQ!**

Video: Exovest in action.

PHOTO: BOEING



Exoskeleton Evolution

What’s now. What’s next?

**A conversation with Dr. Christopher Reid,
Boeing Environment, Health & Safety**

IQ: What’s the current state of exoskeleton technology at Boeing?

CR: Exoskeletons are being deployed as new, required ergonomics personal protective equipment to manufacturing and service jobs that include two hours or more of overhead work. The enterprise exoskeleton numbers have more than doubled since 2020. This growth will continue into 2022 until a natural capacity is reached.

IQ: What types of devices are in use?

CR: Boeing team members benefit from both powered and unpowered (mechanical) exoskeletons for different needs. Postural support exoskeletons were first, such as the shoulder exoskeletons. Ergonomics shoulder injuries are some of the most severe and common across the production workforce.

IQ: What future devices are in work?

CR: Back exoskeleton postural support units are next as well as hand exoskeletons to support prolonged and repeated gripping. And to help mitigate manual material-handling cases involving lifting and carrying or pushing and pulling, full-body-based, powered exoskeleton units are possible.

IQ: What parts of the body most benefit?

CR: Hinges or joints are typically the weakest parts of any structure, as constant use breaks them down over time. Ergonomics-based injuries show up in shoulders, backs, knees and wrists.

IQ: How about ongoing research in the exoskeleton landscape?

CR: The goal is more useful, usable and desirable products. Exoskeletons are becoming lighter, slimmer and smarter. Much of the work is moving toward intelligent systems that can detect when to support and when not to support, to be the most unobtrusive systems to wear and use. Additional research is leading to standards development so the technology doesn’t outpace sustainable standards to aid in safe and effective system development.

PROTOTYPICAL

Boeing human factors and ergonomics engineer Kadon Kyte tests prototypes to qualify those that make sense for deployment and scaling.

Photo taken before Boeing implemented COVID-19 pandemic safeguards.

PHOTO: ALAN MARTS/BOEING



PHOTO: BOEING



FAST
FORWARD

Get up to speed with Boeing's chief scientist of hypersonics

In a recent conversation, **Boeing Senior Technical Fellow and Chief Scientist of Hypersonics Dr. Kevin Bowcutt** covered hypersonics, scramjets, propulsion and why he's also known as the "Father of the X-51A WaveRider." Plus, Bowcutt explains why he's spent more than three decades at Boeing, creating the future of flight out of thin air.



MACH 5 READY

The X-51A WaveRider is mounted under the wing of a B-52H Stratofortress in preparation for a test flight.

PHOTO: PAUL PINNER/BOEING

Hypersonic speed: “There’s no crisp boundary for hypersonic. But it’s typically considered to be Mach 5 and faster. ... It’s really a thermal barrier. As you go faster and faster, the frictional heating of air on the surface makes the temperature go up. And when you go up to Mach 5, you’re above 1,000 degrees Fahrenheit, your surface temperatures. ... By the way, Mach 5 is 1 mile per second. ... That’s a way to think about it.”

The X-51A WaveRider: “The X-51 was one of the first two demonstrations of scramjet propulsion that took 50 years to develop, to perfect, to figure out how to design it and prove that it worked on the ground in wind tunnels. ... The X-51 was like the Spirit of St Louis, the Lindbergh flight, the one that proved that aviation was practical? The X-51 proved that the scramjet engine could be a practical propulsion system.”

“There’s no crisp boundary for hypersonic. But it’s typically considered to be Mach 5 and faster. ... It’s really a thermal barrier. As you go faster and faster, the frictional heating of air on the surface makes the temperature go up.”

DR. KEVIN BOWCUTT, BOEING SENIOR TECHNICAL FELLOW AND CHIEF SCIENTIST OF HYPERSONICS

Recently recognized

Bowcutt was recently named a Hagler Institute Fellow. The Hagler Institute for Advanced Study at Texas A&M University selects its fellows from among top scholars who have distinguished themselves through outstanding professional accomplishments or significant recognition.

“That’s the core of what we do, is we envision the future of flight, whether it’s in space, in the air, and then we create that future out of our imaginations. And that’s pretty cool.”

DR. KEVIN BOWCUTT, BOEING SENIOR TECHNICAL FELLOW AND CHIEF SCIENTIST OF HYPERSONICS

Riding the Wave

The X-51A WaveRider is the first air-breathing vehicle to fly at hypersonic speeds and verify the operation of a scramjet in flight, thanks in part to these Boeing teammates: Craig Christy, Todd Magee, Mark Nugent, Daniel Ortega, Noelle Saccoccio, Paul Seigman, Sergio Vazquez, Joseph Vogel and Ben Wong.

Many others contributed expertise, effort and time to make history happen.

“The X-51 program started a worldwide race to produce similar platforms that will change the future of not only advanced hypersonic weapons systems but the future of space exploration, as many firms and countries try to harness more cost-effective methods of space access,” said Vogel, senior manager in Boeing Research & Technology’s Hypersonic Demonstrator Office.

SCAN CAM HERE,
BOOST YOUR IQ!

Audio: Hear the entire hypersonic conversation.



FAST COMPANY

A U.S. Air Force B-52H Stratofortress carries the X-51A WaveRider near Edwards Air Force Base, California, minutes before the X-51A’s historic flight.

PHOTO: U.S. AIR FORCE

Engineering: “It’s solving problems, taking known science and turning it into technology and things that help humankind. ... And that’s what Boeing does, right? That’s the core of what we do, is we envision the future of flight, whether it’s in space, in the air, and then we create that future out of our imaginations. And that’s pretty cool.”

His three-plus decades at Boeing: “I came to work in the industry because I wanted to ... be the designer of a new, unique flying machine. ... And where else can you come and have the technology, the manufacturing capability, the smart people across any field?” **IQ**



SPACE SCIENCE
NASA astronauts on ISS (opposite), including Christina Koch (above), intentionally damaged the DNA of yeast cells, then allowed those cells to repair themselves, revealing whether the repair restored the DNA to its original order or made errors.

PHOTOS: NASA

Genes in Space

Astronaut safety may fight cancer on Earth



Boeing-sponsored student experiment edits DNA aboard International Space Station

BY STEVEN SICELOFF, BOEING WRITER

The search for a cancer cure has made it all the way to space.

Genetic editing to discover and develop treatments for the effects of deep-space missions on astronauts is closer to reality, following a student experiment conducted on the International Space Station (ISS).

In 2021, ISS marked 21 years of constant human habitation. In that time frame, access to orbital science broadened to include high school students through the Boeing-sponsored Genes in Space program.



REPLICATION STATION

Astronauts made copies of the repaired section of the cell using a process called polymerase chain reaction with a DNA replicator such as the one NASA astronaut Nick Hague is pictured using aboard ISS.

PHOTO: NASA



TEAM TALK

(From left) Students Aarhi Vijayakumar, David Li, Michelle Sung and Rebecca Li speak during a NASA science briefing on April 19, 2019, before their Genes in Space experiment was launched to the International Space Station.

PHOTO: GENES IN SPACE

The technique, known as clustered regularly interspaced short palindromic repeats, or CRISPR, was used on yeast cells aboard ISS to create precise breaks in DNA strands to see how they repaired themselves. The research was published in the scientific journal PLOS ONE by microbiologists and student researchers working with the Boeing-sponsored Genes in Space program.

Being able to do the CRISPR work in space means astronauts on long-duration missions may be able to detect DNA damage and potentially even treat it – just as scientists will do for patients on Earth.

The experiment was part of the Genes in Space-6 payload designed by students David Li, Rebecca Li, Michelle Sung and Aarhi Vijayakumar when they were in high school in Minnesota. The project was led by NASA spaceflight microbiologist Sarah Stahl-Rommel and colleagues, including Boeing senior manager Scott Copeland, the founder of Genes in Space.

DNA ON ISS

NASA astronaut Nick Hague runs an analysis during the experiment exploring how space radiation damages DNA and how cells repair that damage in microgravity.

PHOTO: NASA



“This is the kind of research that opens up many scientific gene-editing opportunities in the future,” said Copeland, who manages all the scientific payloads launched for use on the U.S.-operated part of the orbiting laboratory. “It offers researchers a pathway to additional experiments to drive our discovery that much further.”

Breaks in DNA — the coded protein chain of molecules that detail every aspect of a cell’s function and operation — can lead to mutations and in some cases even cancer. By carefully breaking a DNA molecule, scientists can observe how the repair happens.

Insight from these Genes in Space experiments may fuel future discoveries to prevent mutation and protect people from radiation, which is important for those on Earth but critical for astronauts who travel far beyond the protection of the planet’s magnetic field. **IQ**

Mirror image

With the mountains on the plane matching those in the distance, the Boeing 2021 ecoDemonstrator, an Alaska Airlines 737-9, soars above Washington state’s San Juan Islands. This is the eighth airplane to serve as a flying test bed since the program began in 2012. **IQ**

PHOTO: PAUL WEATHERMAN/BOEING



SURPRISE SASQUATCH SIGHTING

Under the last "a" in Alaska on the Boeing 2021 ecoDemonstrator, sharp eyes can spot a stealthy nod to the Pacific Northwest.

KIM KWOCK/BOEING

SCAN CAM HERE, BOOST YOUR IQ!
Video: Tour the ecoD.



Machines

can see, hear and learn — from humans

Human-centric machine learning in India

BY BHAGYASHREE CHAUDHARI AND DR. SEEMA CHOPRA, BOEING INDIA

Connection is critical. To the untrained eye, the thousands of wires tucked into the walls of every aircraft look like a perplexing puzzle, a snarl of complication. But followed from source to object, each wire leads to a purpose. Each connects to a job the aircraft must execute. If overall aircraft performance can be achieved, even improved, by fewer connections, all the better.

Fewer wires can foster more efficient production and maintenance and, as a result, improve safety and quality.

Digitization is helping in that quest for ideal connectivity using fewer wires. Automation and digital tools make processes more consistent, repeatable and safe. Machine learning (ML) technology and enhanced software tools can strengthen quality and save thousands of labor hours. But to maximize possible gains from these tools, it takes teamwork, creativity and innovation.

WIRED UP

Nikki Then inspects a wire bundle on a tanker in Everett, Washington.

Photo taken before Boeing implemented COVID-19 pandemic safeguards.
PHOTO: MARIAN LOCKHART/BOEING

MACHINE TEAM

Boeing India team members (top, from left) Bhagyashree Chaudhari, Adarsh Vittal Shetty, (bottom, from left) Dr. Seema Chopra, Neha Wani, Anand Kumar, Rohit Kumar and Baby Rachel collaborate virtually to devise a novel approach to machine learning for aerospace application.

PHOTOS: BOEING INDIA



The team at Boeing India Engineering & Technology Center (BIETC) in Bengaluru, in collaboration with colleagues in the United States, has been applying ML technology and automation tools to improve and accelerate the transition of wiring designs from legacy formats to digital enterprise data standards.

**BENGALURU BEAUTY**

The Boeing engineering and technology campus in Bengaluru, Karnataka, will conduct core engineering and research for Boeing's iconic products as well as future platforms. The campus will be one of the largest for Boeing outside of the United States.

IMAGE: BOEING

Upgrade to digital: Wiring design takes time

Wiring designs are the assembly of electrical wires that transmit electrical power within an aircraft. Each design comprises anywhere from 20 to 1,500 components, and each wiring design is associated with several data points.

The upgrade from legacy formats to digital enterprise data standards required extensive manual data formatting. In fact, it took the team, on average, 18 hours to transfer a single design while synchronizing wiring data, capturing cable length and adding individual component part numbers. This also increased the chances of human error. And to update any such incorrectly translated data, an engineer had to redo the entire wire design, which could take more than 120 manual hours.



PROOF OF CONCEPT

A CH-47F(I) Chinook for the Indian Air Force participates in a flight training exercise in Middletown, Delaware. Machine learning increases safety and lowers costs when building H-47 helicopters.

PHOTO: FRED TROILO/BOEING

Critical thinking and creativity: Core tenets for automation

Engineers in the Electrical Design Integration (EDI) group knew manual translation of the designs is a tedious job with repetitive tasks. It is also highly inefficient, as almost 50% of the data may be rejected by the new system due to unacceptable quality. The team brainstormed and defined four core tenets for automation to resolve these issues:

- First-time quality — imperative in all aspects of electrical design.
- Engineering productivity — constantly drives speed and efficacy.
- Digital thread — must exist through all design phases.
- Automation — drives quality and engineering efficiency.

With industry advances in artificial intelligence (AI) and ML, it won't be long before design tools incorporate ML as design aids for the user. Therefore, the EDI team decided to collaborate with the AI/ML team to explore the integration of ML-based automation for translating wire designs.

ML automatically corrected the wiring design with minimal human intervention and validated the design without extensive rework.

The algorithm was implemented for hundreds of Boeing H-47 Chinook heavy-lift helicopter designs for proof of concept. The ML model resulted in harness deliveries with expected project design quality and a 30% reduction in design cycle time.

The team automated the process by using image processing for reading and extracting details from the wiring design and used natural language processing to visualize the relationship between various components in the form of knowledge graphs. The AI/ML-based executable automation tool is capable of designing

hundreds of wiring diagrams with required design properties automatically — and in a short span of time.

There's immense potential to reuse and replicate the technique. The model was successfully implemented on some key defense aircraft as well. The team is now leveraging its early success to develop a proof of concept to automate migration of wiring designs in commercial aircraft. This model will provide a significant opportunity for data migration savings in terms of labor hours and cost.

CHINOOK INSIDE LOOK

Technician Keith Repko performs a wiring installation in a Chinook helicopter at the Boeing site in Ridley Park, Pennsylvania.

Photo taken before Boeing implemented COVID-19 pandemic safeguards.
PHOTO: BOB FERGUSON/BOEING

Machine learning plus machine teaching: Adds up to aerospace improvement

Human-centric machine learning happens when the machines learn from the data, from history and from the subject matter expert. Then machine teaching occurs when algorithms learn from electrical engineers.

The strong working relationship between the EDI engineering domain experts, embedded software engineers and ML experts led to this significant process improvement. By recognizing the human aspect while developing the ML models, this system still keeps domain knowledge at the center of the entire development cycle.

It paves the way for newer possibilities for human-centered ML.

As the Boeing India team embraced the opportunity to convert legacy tool data to digital enterprise standards using ML algorithms, they demonstrated creativity and engineering innovation. As a result, they generated a customized business solution that brings the best out of analytics/ML methodology — and could be applied across the enterprise. **IQ**



PHOTO: YUICHIRO CHINO/GETTY



ABOUT THE AUTHORS

Bhagyashree Chaudhari (left) is an engineering manager in the Electrical Design Integration group at Boeing Engineering, Test & Technology in India. She leads an Electrical Wiring and Harness engineering team that supports multiple platforms across various business units.

Dr. Seema Chopra (above) is a Boeing Technical Fellow in artificial intelligence and a member of the System and Analytics group at Boeing Research & Technology in India. Her current work includes developing next-generation advanced health management technologies using real-time streaming airline data and big data platforms.

PHOTOS: BOEING

The space between

How to get the word out
without letting the word get out

BY KEN HARDMAN, BOEING TECHNICAL JOURNAL FOUNDER AND CHAIR

Celebrating a decade of discussion, the founder of the Boeing Technical Journal revives some of his original thoughts from the debut edition and demonstrates how this conversation among inventors nurtures innovation.



As you reflect on the dilemma, you are caught between two good but conflicting principles: getting the word out and protecting company value.

You've just completed significant research for a project, capturing your work with references, theory, derivations, analysis, experiment and test. Knowing that your results could benefit the work of others, you feel motivated to share it in a reputable journal and add to the world's body of knowledge.

In conference with your manager, you both agree, however, that releasing this information might deprive the company of a competitive advantage. Therefore, your paper is confirmed proprietary and, for the time being, must remain as protected intellectual property. As you reflect on the dilemma, you are caught between two good but conflicting principles: getting the word out and protecting company value. And yet, you feel there must be a way to satisfy both.

Consider your motivation. Is it recognition by professional peers? Notoriety? Verification of your work? Or do you desire to see your work put to good use? If you are like me, it is several of these factors. You reason: Is external publication the only way to obtain value to both you and the company? What about internal distribution? In a sizable company, couldn't I find reviewers, receive recognition by my professional peers, verify research and have my work put to good use? Innovative thoughts click in. How about a high-quality, peer-reviewed, internal journal for proprietary scholarly works?

You need help getting such a grassroots journal off the ground. You need to know how other employees feel about the idea and the best way to proceed according to company policies and procedures. You figure you are not alone in your quandary. In fact, you realize you have the tools to find others with similar concerns and needs, using your company's internal social network.

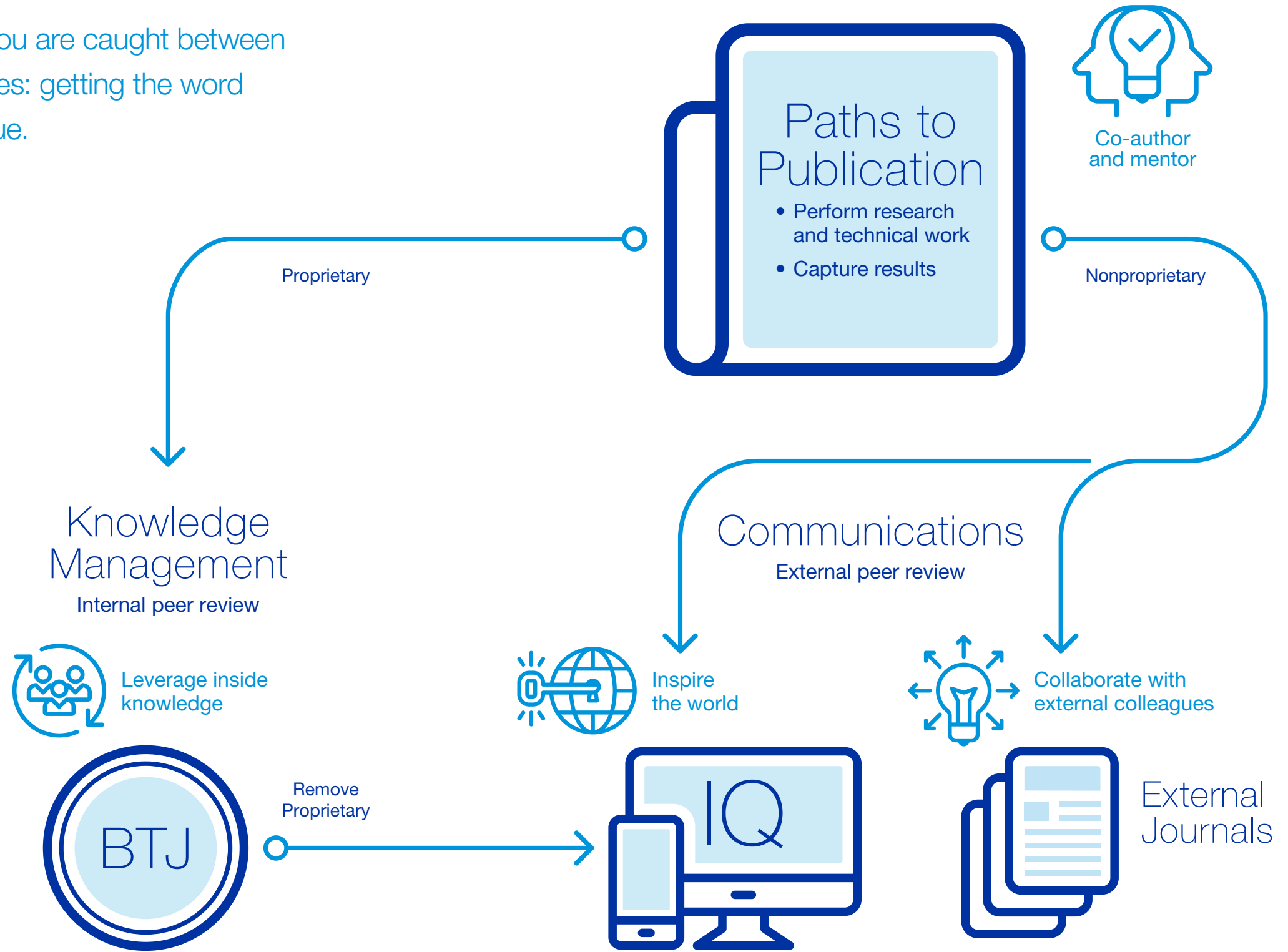

GRAPHIC: BOEING

In a matter of days, you receive a handful of positive responses with encouragement to move to the next level. In our case, we created a group called Boeing Technical Journal (BTJ) and wrote a well-thought-out description of our vision with a draft of notional processes to stimulate discussion.

Colleagues began to join our group. Many added comments, recommendations, concerns and support to the discussion threads. Membership grew quickly, confirming that many peers in the company had strong interest. Help was offered by editorial and subject matter experts, members of the company technical community and others who felt the need to get their work into the hands of appropriate users.

Over the course of one year, presentations were made, surveys were conducted, volunteer committees were formed, an executive sponsor was identified, procedures were developed, a call for papers was circulated and paper submittals commenced. Subject matter experts throughout the company compiled valuable work in a scholarly form, submitted to rigorous peer review and shared knowledge for their collective success.

The Boeing Technical Journal was born.

During its first decade, the BTJ engaged more than 400 employee authors and co-authors, as well as 600 peer reviewers and editors, resulting in more than 200 high-quality, distinct papers on diverse topics important to Boeing. In addition to the expansion of working relationships and networks, knowledge within BTJ papers was leveraged, increasing value throughout the enterprise.

For example, “Checklists to Enhance Safety,” by Daniel Boorman and William Higgins, resulted in author opportunities to consult and increase critical process safety on multiple programs. “What Is a Game-Changing Design,” by Dr. Miriam Grace, expands company understanding of design principles and practices and promotes the company Human-Centered Design movement and User Experience Community of Practice. “Model and Analysis of an Active Cradle System,” by Dr. William Ferng and Dr. Jeffrey Hunt, enhances discussions to improve aircraft manufacturing methods.

The BTJ demonstrates how a large organization can find the space between.

It is possible to develop proprietary technology, obtain broad traditional peer review and share knowledge while still maintaining knowledge protection. Employees are encouraged to develop and capture (and help others capture) knowledge, then get the word out, while limiting access where necessary.

You, too, can find ways in your organization and in your career to find resolutions to conflicting requirements. With some careful thought and collaboration, you can find the space between. **IQ**

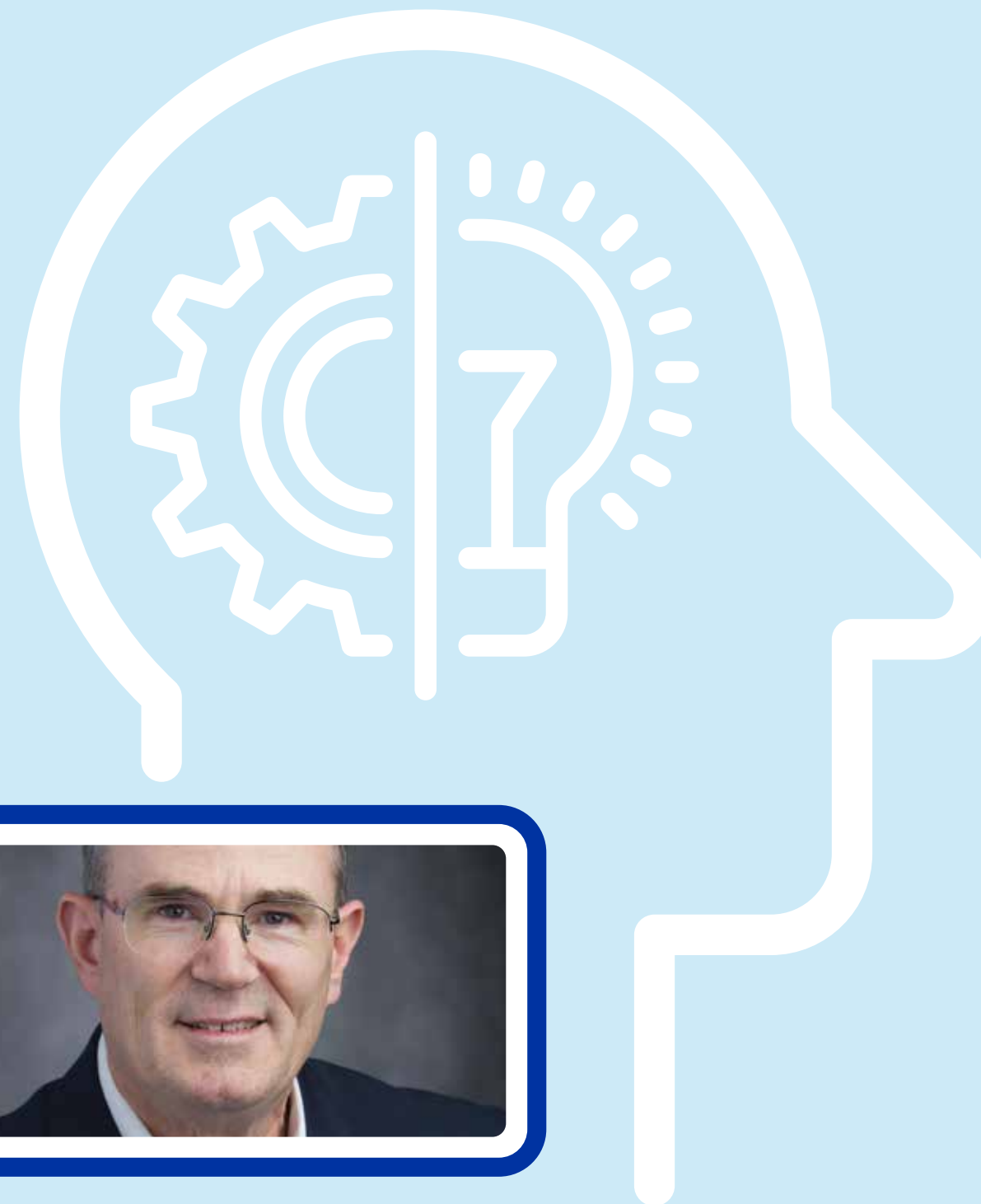

ABOUT THE AUTHOR

Systems engineer and Associate Technical Fellow Ken Hardman founded the Boeing Technical Journal in 2010 and is the host of “BTJ Reflections,” a Boeing internal video series featuring interviews with BTJ authors. In his three decades at Boeing, he’s worked on satellites, missiles, telescopes and passenger jets. He’s mentored hundreds of college engineering students and published “Engineering Stories,” a book for youth, young adults and educators that offers an inside look at working on teams and innovatively solving engineering problems.



GRAPHIC: BOEING

“
It's just
around the
corner
”

“
It'll change
the world
”

“
It's the next
big thing!
”

CHIP OFF THE OLD BLOCH

Author Marna Kagele appears in the qubit “Earth” in quantum information theory, known as a Bloch sphere, named after Swiss American physicist Felix Bloch. Uninhibited by the limitations of classical bits, qubits can have a value representing any point on the surface of a sphere.

IMAGE: JACKIE NIAM/GETTY
PHOTO: MARIAN LOCKHART/BOEING

Quantum computing, from promise to value

How to harness the advantage

BY MARNA KAGELE, BOEING ENGINEERING, TEST & TECHNOLOGY

Quantum computing evangelists claim what may take a classical computer a week could be accomplished by a quantum computer in one second.

Quantum computing offers the potential for opportunity, technical breakthroughs and far-reaching advantages for businesses everywhere. But let's separate the hype from reality. What value can businesses get from quantum computing capabilities both now and in the future?

Quantum Computing

IT'S IN THE NUMBERS

Quantum computing is a method of performing calculations that is based on unique phenomena found in quantum mechanics. For example, classical computers use bits to perform calculations, and each bit can have a value of 0 or 1.

In quantum computing, calculations are performed using qubits. Because of the quantum characteristic of superposition, qubits can have a value of 0, 1 or a combination of both. Qubits can also use the quantum capability of entanglement to correlate any two qubits, and this enables problems to be solved in new ways.

QUBIT =
Quantum + Bit
(NOUN / 'KYŪ-BƏT)

A unit of computing information that is represented by a state of an atom or elementary particle (such as the spin) and can store multiple values at once due to the principles of quantum mechanics.

SOURCE: MERRIAM-WEBSTER

While the promise of quantum computing has indeed been circulating for more than 40 years, it seems that real-world implementation is finally in sight. There is a marked increase in the amount of research that is being mobilized to bring quantum computing capability to fruition. We see evidence of this push in recent global growth in funding investments, job openings, new market entrants and technical publications. There are also consortia, government investments and business-focused conferences (not just technical conferences).

Startup companies are emerging more than ever, covering a portfolio of capabilities from hardware to software, algorithms and networking. And beyond just physics, we see new college programs focused on building quantum computing skills for the future.



There are several potential scenarios along the development path for quantum computing capability. It's unknown exactly how far along this path technology will evolve to enable computation advances. But it's worth exploring the value businesses can leverage in each.

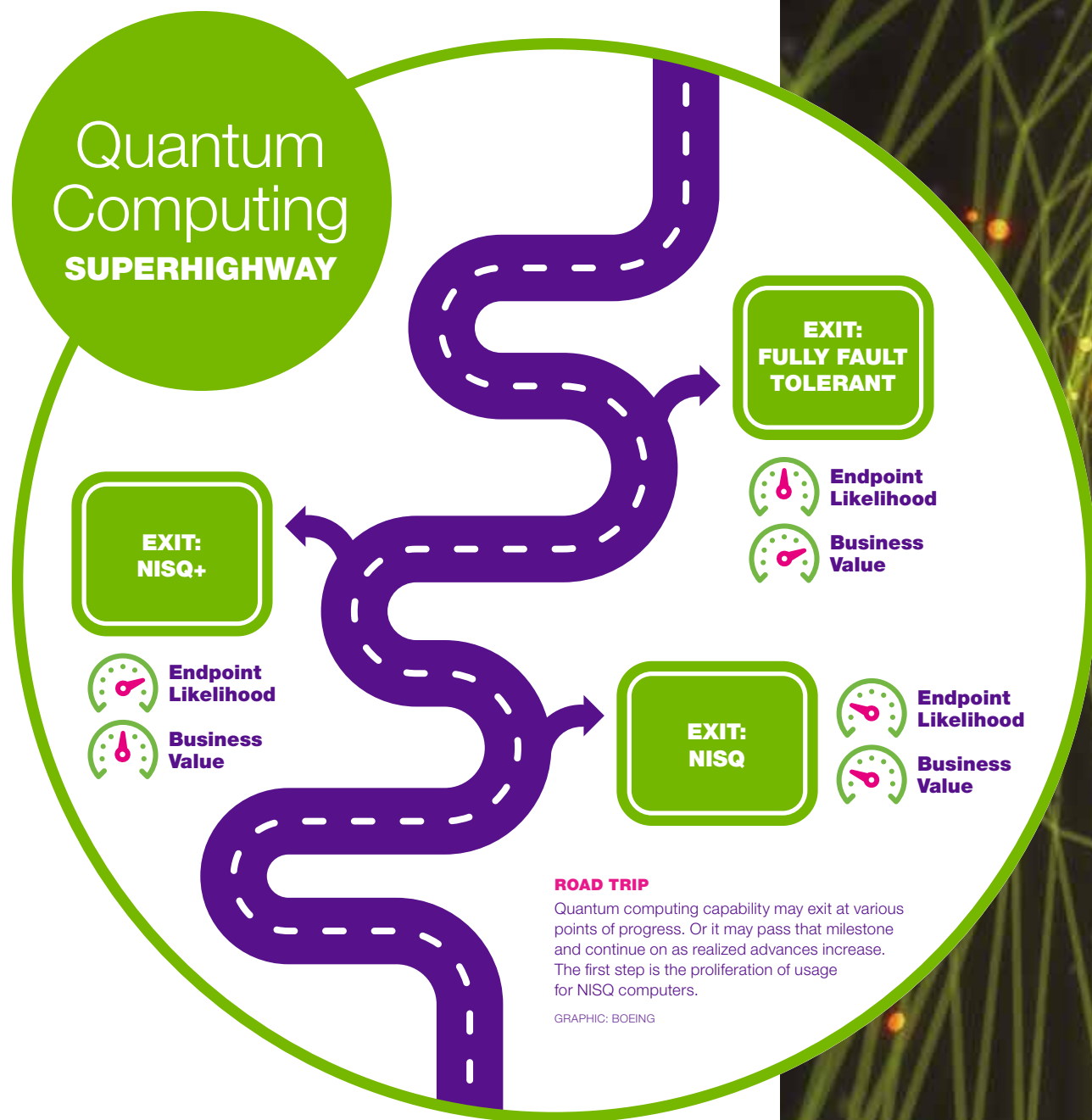

The good news is that noisy intermediate-scale quantum (NISQ) computers already exist.

They're "noisy" because they are susceptible to errors and intermediate scale because they do have a significant number of qubits, though not enough to handle problems at scale.

Research using NISQ computers is ongoing for real-world computation challenges in the finance, manufacturing and automotive industries, among others. Hybrid classical-quantum algorithms have proved effective at demonstrating the potential power of quantum computing and using it for the portions of problems it is best at solving.

With all the effort and research going into the field, it is likely there will be additional advances following the road maps produced by several hardware manufacturers that all point toward increased NISQ capability by 2023. With this high probability of additional NISQ capability and accompanying algorithm development, we can assume with confidence that additional quantum volume will lead us to a place of solving useful problems for many industries.

If we then say development leaves off there — no more advances come to fruition after this stage — where does that leave us? At that point, the cost of quantum computer creation, maintenance and operation would still be high. That means access costs for companies and researchers would also be high.

Some serious evaluation of the gain versus cost would need to be evaluated, and there is potential that the costs could be prohibitive. However, if hardware improvements were made, there could still be value in the types of calculations possible, and there would be benefit. While the impact of this scenario of limited NISQ computer development as a finish line is low, it also shows there are potential futures in which the promise of quantum computing would be low.

Endpoint Likelihood: Low
Business Value: Low

Bench- marking WITH QUANTUM VOLUME

Today's quantum computing systems tend to have high error rates and are based on different technologies. As advances are made, comparing different systems is useful to understand their relative performance.

You may hear comparisons made using simply the number of qubits in a given system, but that is only part of the answer. Factors like qubit coherence time, qubit connectivity and gate error rates significantly affect the computation power of the system as a whole. A holistic measure is needed for a meaningful comparison.

One consistent benchmark has yet to be agreed upon, but a leading measure is quantum volume. This metric is the resulting value from running a specific protocol on a given quantum computer. A better system will have a higher number. This doesn't tell the whole story about a system but is a solid starting point for comparison.

NISQ+ QUANTUM LEAPS



The most likely scenario for quantum computation is that we pass through the initial NISQ stage and end up in a future with NISQ computers that have had major improvements in the number and quality of their qubits. Errors are low because of extensive correction schemes, which enables larger problems to be solved with increased precision.

This level of capability opens a wide range of value for companies and researchers looking to capture value from quantum computing. At this level, it is highly likely that complex optimization decisions could be made more effectively than they are with today's classical methods.

Chemistry-related discovery could be significantly reframed to hone in on molecules with desired properties. The scale that could be achieved with models would be significant for understanding complex systems. The cost for operation and access to such quantum computers could still be a limiting factor.

But it is assumed that technical advances would bring those costs down, and when combined with the additional computation capability enabled, this would offer high value and realize the promise we anticipate. In other words, the value of solving the more complicated problem will more than offset the high cost of calculation. This is similar to the early mainframe era of computer science.

Endpoint Likelihood: High
Business Value: Medium

Fully Fault Tolerant FULLY REALIZED



Now to the case where we continue even further down the development path and the full potential is realized with major breakthroughs that lead to universal fully fault-tolerant quantum computers with extremely high quantum volume. We know there is a considerable amount of effort behind this, but uncertainty remains. The time frame is undetermined, if it will happen at all. This is where we see the most divergence in predictions and discussions among experts.

History of Safety

70-year-old document spells it out

BY MIKE LOMBARDI, BOEING HISTORICAL SERVICES

For the moment, though, assume this does happen, even in the next decade. This kind of development would truly deliver the promise of quantum computing in terms of speed, solving currently intractable problems, the replacement of costly physical testing and new design paradigms.

In this situation, companies should think about what their new, most difficult issues would be. For example, if a manufacturing setting has optimization limits that could be easily solved, what would the next big challenge be? And assuming involvement with quantum computing as it evolved to this stage of capability, is there another use for the NISQ computation that is now less capable but perhaps still useful? Could it be retrofitted or adapted for certain types of problems or other purposes?

Endpoint Likelihood: Medium
Business Value: High

What Now
ALL THE
ABOVE



In all of the previous scenarios, there are focus areas that are useful to think about and work toward solving now while waiting to see which scenario comes true.

First, identify the problem set. Determine the current computation challenges and which ones lend themselves to quantum computation or hybrid methods. Keep track of algorithm development and research results to have a clear sense of how and when the promise of quantum computing could affect work.

As advances are made, there will be a duration in which applying quantum computing capability brings a unique advantage to a company and thus has the potential to offer value before it becomes a given for problem-solving. Prepare for this time by building internal skill sets and application knowledge that will offer an edge. Consider how to educate your current employees and how to contribute to education programs, ensuring a future quantum-literate workforce in five to 10 years.

One could also think about the value derived from the research that advances understanding in quantum physics but perhaps does not lead to advances in quantum computing. For example, could there be additional gain from information about qubit research that didn't pan out, unsuccessful algorithms that didn't produce desired results or hardware advances that could be applied in new contexts?

While there is still much uncertainty about how quantum computing will develop in the long run, it is clear that significant advances have been made, and there is more funding and effort than ever before pushing to advance this technology space. It is worthwhile to take steps now to ensure we are prepared to leverage this capability. **IQ**

ABOUT THE AUTHOR

Marna Kagele is a Boeing Technical Fellow in systems engineering and strategic foresight and a real-life rocket scientist.

During World War II, the demanding schedules, the number of new workers and the new procedures for mass-producing airplanes required constant vigilance for safety.

FIVE GRAND

Builders, riveters and designers at Plant 2 in Seattle surround the 5,000th B-17 Flying Fortress built after the attack on Pearl Harbor. Valuable safety lessons were learned during the war effort.

PHOTO: BOEING HISTORICAL SERVICES

A safety document was printed soon after the war and reflects much of what was learned in those hectic times.

The document came straight from Fred Laudan, vice president of Manufacturing, who had overseen the assembly of every Boeing airplane except the original B & W.

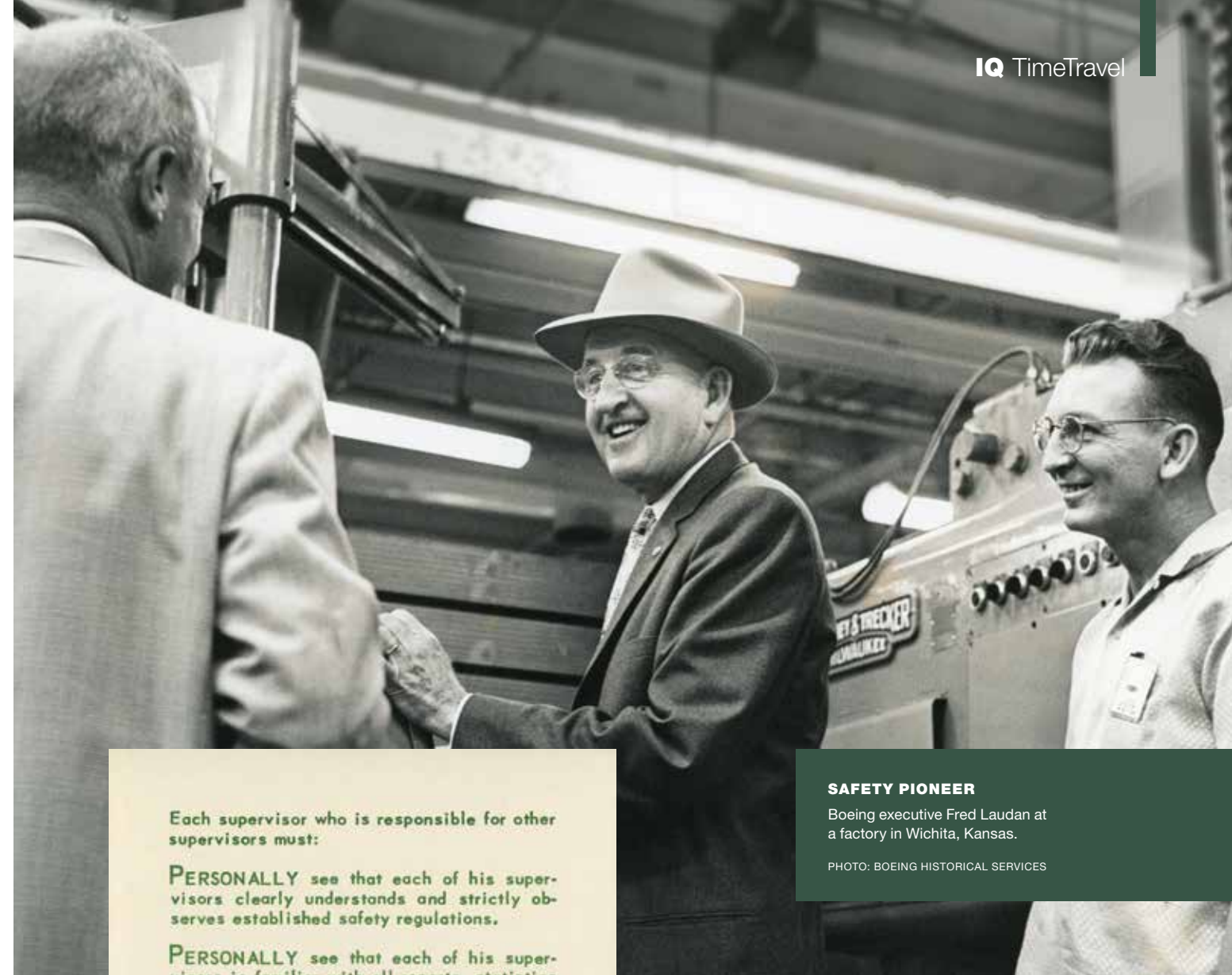

SAFETY PIONEER

Boeing executive Fred Laudan at a factory in Wichita, Kansas.

PHOTO: BOEING HISTORICAL SERVICES

RESPONSIBILITY of the SUPERVISOR in the SAFETY PROGRAM



BOEING AIRPLANE COMPANY

Each supervisor is directly responsible for the operation of an effective safety program in his organization. In order to assure its success he must:

PERSONALLY see that each employee, both old and new, receives proper safety instructions.

PERSONALLY see by constant follow-up that safety instructions are understood and followed.

PERSONALLY see that each employee does his work in a safe manner and under safe conditions.

PERSONALLY see that unsafe conditions are eliminated and unsafe practices are corrected.

PERSONALLY see that each employee is provided with the proper safety equipment and that such equipment is properly used.

PERSONALLY see that cleanliness and orderliness are always maintained.

PERSONALLY see that accurate reports of accidents, injuries and other safety matters are made out and forwarded to the proper personnel.

PERSONALLY see that each employee realizes the benefits of working safely.

Each supervisor who is responsible for other supervisors must:

PERSONALLY see that each of his supervisors clearly understands and strictly observes established safety regulations.

PERSONALLY see that each of his supervisors is familiar with all reports, statistics and other data which are a part of the safety program.

PERSONALLY see that the safety program is discussed periodically at regular or special supervisory meetings in order to stimulate interest and pass along safety ideas and information.

PERSONALLY see that each supervisor is safety conscious.

The Safety Unit can answer any specific questions regarding the safety program. Safety is often common sense. Each supervisor should always remember that safety neither begins nor ends with a set of rules.

Fred P. Laudan
FRED P. LAUDAN
Vice President Manufacturing

His thoroughness, expertise and leadership were so respected that he was made a member of the board of directors.

PERSONAL RESPONSIBILITY

This document outlining safety responsibilities was distributed to supervisors throughout Boeing just after World War II.

IMAGES: BOEING HISTORICAL SERVICES

FACTORY FLOOR

Workers gather for a B-50 fuselage join at Plant 2 in Seattle in 1947.

PHOTO: BOEING HISTORICAL SERVICES



Think

Talk

Act.

. Safety

Laudan spelled out safety instructions that remain relevant more than seven decades later.

He emphasized that managers had a personal responsibility not only to lead in safety initiatives but also to clearly communicate those initiatives to their team — to **“Think,” “Talk” and “Act.”**

Boeing currently encourages employees to “Seek, Speak and Listen,” showing that the values championed throughout the company’s history continue today. **IQ**



One Day at a Time.

SAFETY SIGNS

Reminders at Boeing sites worldwide encourage all to pursue zero injuries and incidents.

IMAGE: BOEING

PatentPower

Boeing's latest ideas and technical breakthroughs recently granted or published by the U.S. Patent and Trademark Office

Weight Watcher

U.S. Patent: 10,989,585

"Methods and apparatus to measure mass in low gravity environments"



Inventor: Aerospace engineer Kevin Cannon is a weight and mass properties lead for Boeing Space and Launch Engineering.

PHOTO: BOEING

BY MELANIE MORRILL, BOEING WRITER

Even astronauts have to take out the trash. Imagine traveling in space to Mars. On such a trip, garbage is indeed part of the day to day of human activity in a spacecraft.

In such an exacting environment, the truly mundane has to be accounted for. Traveling millions of miles requires precise trajectories to ensure the spacecraft's speed is just right. As waste is jettisoned, the vehicle has less mass, changing how much fuel is needed to accelerate or decelerate.

But how do you weigh a bag of trash in zero gravity? While working with NASA's Commercial Crew Program, aerospace engineer Kevin Cannon discussed with colleagues the ramifications of cargo transfers after travel in orbit. "We have a very small tolerance, and we need to be accurate with our numbers," Cannon said, noting that mass is measured to 0.04% accuracy.

Current devices in low- to no-gravity environments cannot typically measure smaller masses, such as an astronaut's weight change after eating or lightweight cargo transferred to and from vehicles. Cannon saw the opportunity to create a portable device and method for measuring the mass of smaller objects that change over time or are the composite of smaller items.

His efforts resulted in his first Boeing patent, U.S. Patent No. 10,989,585, "Methods and apparatus to measure mass in low gravity environments." Cannon's method utilizes electromotive force to induce a change in momentum between the measurement device and the item being measured. A combination of inertial measurement units provides the relative velocities of the device and item. By knowing the mass of the measurement device and the relative velocities, the mass of the item can be determined.

Cannon's consideration of weight and mass and how those properties affect flying objects is a lifelong pursuit. When he was younger, Cannon thought he wanted to be a pilot. After his first observer flight, however, he realized that while flying was fun, it would probably not hold his attention.

He switched his major from aviation to aerospace engineering and now greatly enjoys being one of a select group of mass property engineers at Boeing. "We're involved in the very beginning of a program," he explained. And Cannon and his teammates remain to the finish, when they get to watch what they helped build "sail, fly or drive away." **IQ**

Example Spacecraft

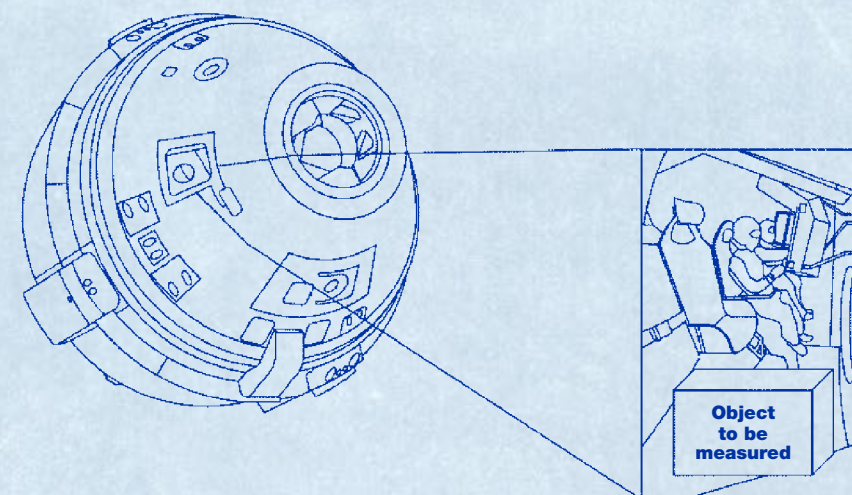

How do you weigh a bag of trash in zero gravity?

MASS AND MANEUVERS

From the official U.S. patent: "The example spacecraft is an orbital vehicle that is placed into a planetary orbit and maintains a path within that orbit. ... Maneuvers to change orbit and/or move the spacecraft onto an orbital path can be affected by mass distribution of objects within the spacecraft. Accordingly, it may be advantageous in some examples to measure a mass of at least one object within the interior to account for any potential inertial effects."

GRAPHIC: BOEING

Inertial Mass Measurement Apparatus: How It Works

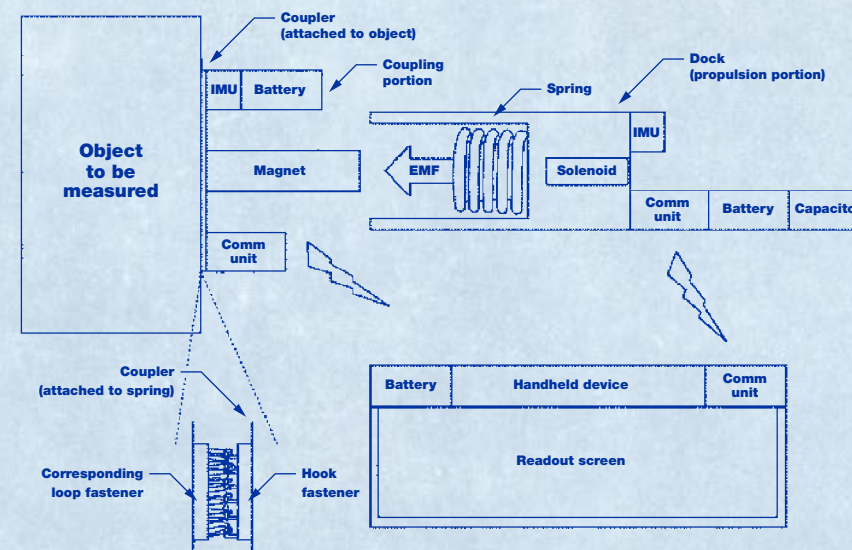

IMU = Inertial measurement unit EMF = Electromotive force COMM UNIT = Communication unit

MEASURED BY MOTION

From the official U.S. patent: "To determine a mass of the object based on causing relative motion between the dock and the coupling portion, the handheld device ... receives movement data from the communication unit ... during relative motion of the dock with respect to the coupling portion. In turn, the example handheld device calculates the mass of the object based on this movement data."

GRAPHIC: BOEING

SCAN CAM HERE, BOOST YOUR IQ!

View the official U.S. patent.



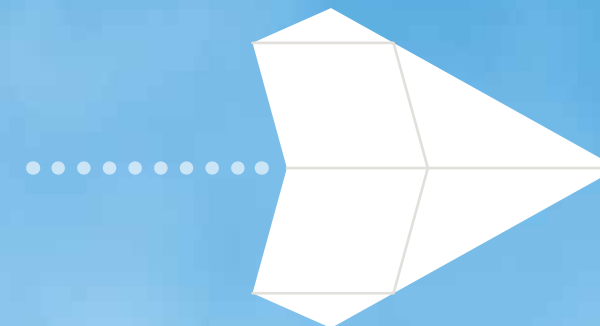

Inspiring
the future
of flight



New Newton Room

Students learn to fly on the flight simulators at Poland's first permanent Newton Room, which opened at Łódź University of Technology. Supported by Boeing and FIRST Scandinavia, the learning modules relate to aviation to inspire young students to explore science, technology, engineering and math.

Photos taken in accordance with local COVID-19 pandemic safeguards.
PHOTOS: FIRST SCANDINAVIA



Festival of Flight

More than 1,000 students competed in the seventh Boeing-IIT National Aeromodelling Competition in India, hosted by Boeing in partnership with five Indian Institutes of Technology (Delhi, Kanpur, Kharagpur, Madras and Bombay). The 2021 competition was virtual, with teams submitting videos that captured the process of designing, building and demonstrating a glider and a catapult launch mechanism to achieve maximum endurance and flight time. **IQ**



OUT TO LAUNCH

(Above) The glider designed by the team from Priyadarshini College of Engineering, Nagpur, is poised and ready for its winning flight in Ahmednagar, Maharashtra.

(Top right, from left) Hakimuddin Naeem Hirani and Mitesh Dawale, from Centre Point School, Wardhaman Nagar, Nagpur, Maharashtra, craft their team's "Beam Glider."

(Bottom right) Pratik Sahu and the team from Kendriya Vidyalaya No. 2, CRPF Colony, Bhubaneswar, Odisha, created the "Albatross."

Photos taken in accordance with local COVID-19 pandemic safeguards.
PHOTOS: BOEING



SCAN CAM HERE,
BOOST YOUR IQ!

Video: See Team Tactical
Takeoff's glider soar in India.

INNOVATION DRIVEN BY INCLUSION



Creating the world's most innovative aerospace products and services requires a diverse and inclusive global team. Join us.

boeing.com/careers

Boeing is an Equal Opportunity Employer. Employment decisions are made without regard to race, color, religion, national origin, gender, sexual orientation, gender identity, age, physical or mental disability, genetic factors, military/veteran status or other characteristics protected by law.





HIGH ON THE WARTHOG

U.S. Air Force Capt. Curtis Lackey, from the 442nd Fighter Wing, taxis an A-10C Thunderbolt II on the runway after landing in St. Louis for a visit with the Boeing Global Services A-10 team. First deployed in March 1976 and manufactured by Fairchild Republic, the A-10 was specially designed for close air support of ground forces. The twin-engine jet, nicknamed the "Warthog," can be used against light maritime attack aircraft and ground targets such as tanks. Boeing is currently under contract to deliver new wings and wing parts for the A-10, which the Air Force intends to fly into the early 2030s.

PHOTO: ERIC SHINDELBOWER/BOEING

YOUR IDEAS IN ORBIT



Our engineers design and build the future of space exploration and commercial access. Join our team and do work that has a global impact.

[Boeing.com/Careers](https://www.boeing.com/careers)

Boeing is an Equal Opportunity Employer. Employment decisions are made without regard to race, color, religion, national origin, gender, sexual orientation, gender identity, age, physical or mental disability, genetic factors, military/veteran status or other characteristics protected by law.

